

## ABSTRACT

Title of Thesis: A DIRECT TO GROUND ARCHITECTURE FOR  
SUPPORTING COMMUNICATIONS FOR THE  
INTERNATIONAL SPACE STATION

Degree candidate: Alex Think Nguyen

Degree and Year: Master of Science, 2001

Thesis directed by: Dr. Michael Hadjitheodosiou  
Dr. John Baras  
Institute for Systems Research

The deployment of the International Space Station (ISS) has opened new opportunities for research in space, providing a unique platform for tele-science, microgravity experiments, human physiology studies, and earth observation. In order to control, gain data from, and interact with these activities from the ground, a communications system that can support this broad range of applications needs to be established.

In this thesis, three communications architectures for the ISS are discussed: 1) using NASA's Tracking Data Relay Satellite System (TDRSS), 2) using emerging broadband commercial satellite systems to relay data to the ground, and 3) communicating directly to the ground ("DTG"). The thesis will focus on the latter option, DTG, and establish a methodology for determining the optimum placement of

ground terminals for this type of service. A simulation model is developed for a large image file download application, and a detailed coverage analysis of the ISS communicating directly to these ground facilities is performed. In addition, a bottom-up cost estimate of this architecture is developed and compared to the costs of the other two architectures. The results show that the direct to ground architecture cost is competitive with that of the other architectures, and offers scalability for non-real-time applications. Coverage provided by commercial Ka-band satellite systems is about the same as that achieved by direct to ground, but its services will likely not be tailored to the needs of the ISS. The TDRS system provides complete coverage, and is therefore good for real-time applications such as videoconferencing.

A DIRECT TO GROUND ARCHITECTURE FOR SUPPORTING  
COMMUNICATIONS FOR THE INTERNATIONAL SPACE STATION

By

Alex Think Nguyen

Thesis submitted to the Faculty of the Graduate School of the  
University of Maryland, College Park in partial fulfillment  
of the requirements for the degree of  
Master of Science  
2001

Advisory Committee:

Professor John Baras, Chair, Advisor  
Dr. Michael Hadjitheodosiou, Advisor  
Professor Mark Austin

© Copyright by  
Alex Thinh Nguyen  
2001

## DEDICATION

To my wife and parents

## ACKNOWLEDGEMENTS

I am grateful to my advisors Dr. John S. Baras and Dr. Michael Hadjitheodosiou for their direction and support. I am particularly thankful to Dr. Hadjitheodosiou for his continuous support throughout my thesis work and the published papers that we have co-authored.

## TABLE OF CONTENTS

|            |   |    |
|------------|---|----|
| Chapter 1: | Introduction.....   | 1  |
| 1.1        | Motivation / Significance.....                                    | 4  |
| 1.2        | Contribution of Thesis / Research.....                            | 5  |
| 1.3        | Organization of Thesis .....                                      | 7  |
| Chapter 2: | Architectures & Methodology .....                                 | 9  |
| 2.1        | Option 1: Using existing TDRSS.....                               | 10 |
| 2.2        | Option 2: Using commercial satellite systems as relay .....       | 14 |
| 2.3        | Option 3: ISS direct to Ka-band ground terminals .....            | 16 |
| 2.4        | Methodology & Scope .....   | 17 |
| Chapter 3: | Coverage Analysis .....   | 20 |
| 3.1        | Effect of Longitude & Latitude of Stations on Coverage .....      | 20 |
| 3.2        | Effect of station Elevation angle on coverage .....               | 23 |
| 3.3        | Effect of ISS antenna scan angle on coverage .....                | 26 |
| 3.4        | Effect of station elevation angle and ISS antenna scan angle..... | 29 |
| 3.5        | Coverage with Select Ground Stations .....                        | 31 |
| Chapter 4: | Analysis of Imaging Application.....                              | 37 |
| 4.1        | Assumptions.....  | 37 |
| 4.2        | Coverage Results.....   | 38 |
| Chapter 5: | Cost Analysis & Comparison.....                                   | 42 |
| 5.1        | Cost Breakdown Structure .....                                    | 43 |
| 5.1.1      | Space Segment .....   | 45 |
| 5.1.2      | Launch Segment.....   | 45 |
| 5.1.3      | Ground Segment .....  | 46 |
| 5.1.4      | Operations and Maintenance.....                                   | 46 |
| 5.2        | Costing Methods .....   | 46 |
| 5.3        | Ground Segment .....  | 49 |
| 5.4        | Operations & Maintenance .....                                    | 50 |
| 5.5        | Space Segment .....   | 51 |
| 5.6        | Launch Segment.....   | 52 |
| 5.7        | Summary of Costs.....   | 53 |

|                  |   |    |
|------------------|---|----|
| 5.8              | Comparison with Commercial Constellation..... | 55 |
| 5.9              | Comparison with TDRSS .....                   | 58 |
| Chapter 6:       | Summary and Future Work.....                  | 61 |
| 6.1              | Summary.....                                  | 61 |
| 6.2              | Future Work .....                             | 64 |
| Appendix A.....  |   | 66 |
| REFERENCES ..... |   | 78 |



## LIST OF TABLES

|  |    |
|--|----|
| Table 2.1. Comparison of current and new TDRSS services. [ ] .....                   | 13 |
| Table 2.2. Emerging Ka-band commercial satellite systems. [],[ ] .....               | 15 |
| Table 3.1. Coverage data for varying station latitude and ISS cone angles.....       | 29 |
| Table 3.2. Coverage data for varying elevation angle and cone angle. ....            | 29 |
| Table 3.3. Coverage provided by each of the 20 selected ground stations. ....        | 33 |
| Table 3.4. Cumulative Coverage and throughput for stations. ....                     | 35 |
| Table 4.1. Cumulative access data and throughput for 31 stations.....                | 41 |
| Table 4.2. Complete chain access and throughput for 6 US ground stations. ....       | 41 |
| Table 5.1. Summary of Ground Segment costs. ....                                     | 50 |
| Table 5.2. Summary of Operations and Maintenance costs.....                          | 51 |
| Table 5.3. CERs and costs for RDT&E of ISS antenna & communications systems. ....    | 52 |
| Table 5.4. CERs and costs for production of ISS antenna & communications system. ... | 52 |
| Table 5.5. Launch Segment costs summary. ....  | 53 |
| Table 5.6. Total cost summary of ISS direct to ground communication system. ....     | 54 |
| Table 5.7. Summary of cost per unit of data for ISS direct to ground system.....     | 54 |
| Table 6.1. Percentage coverage provided by three architectures. [],[ ] .....         | 62 |
| Table 6.2. Cost per Megabyte for three architectures. [15],[16].....                 | 62 |
| Table 6.3. Advantages and disadvantages of three architectures.....                  | 63 |

## LIST OF FIGURES

|  |    |
|--|----|
| Figure 1.1. Sample matrix of communications requirements and applications. ....                                      | 1  |
| Figure 1.2. Access methods to mission spacecraft.[2] .....   | 3  |
| Figure 2.1. Alternative communications architectures to/from the ISS .....   | 10 |
| Figure 2.2. Topology of NASA TDRSS. ....   | 11 |
| Figure 2.3. NASA TDRSS along with ISS ground track.....  | 11 |
| Figure 2.4. Description of TDRS antennas. [] .....   | 12 |
| Figure 3.1. Distribution of stations at 0-longitude and varying latitudes. ....                                      | 21 |
| Figure 3.2. Coverage over 10 days for varying station latitude. ....   | 22 |
| Figure 3.3. Distribution of stations at arbitrary longitudes. ....   | 23 |
| Figure 3.4. Coverage with respect to station latitude for varying min. elevation angles..                            | 24 |
| Figure 3.5. Coverage with respect to station minimum elevation angle.....  | 25 |
| Figure 3.6. Coverage with respect to latitude for varying ISS antenna scan angles. ....                              | 27 |
| Figure 3.7. Coverage with respect to ISS cone angle. ....  | 28 |
| Figure 3.8. Coverage for varying elevation angle and cone angle.....   | 30 |
| Figure 3.9. Selected NASA ground stations at high latitudes shown with access circles.                               | 32 |
| Figure 3.10. Selection of 20 NASA ground stations for 75 deg scan angle. ....  | 32 |
| Figure 3.11. Min, Max, Mean Total coverage for selected ground stations. ....  | 34 |
| Figure 4.1. Selection of stations for best coverage with 60 deg scan angle .....                                     | 38 |
| Figure 4.2. Min, max, mean, total coverage for selected stations.....  | 39 |
| Figure 4.3. Ground track of 6 US ground stations showing ISS access. ....  | 40 |
| Figure 5.1. Work breakdown structure for direct to ground communication system. ....                                 | 44 |
| Figure 5.2. Proposed Astrolink system. ....  | 55 |
| Figure 5.3. Model of Astrolink satellite covering main continents with access to ISS. ..                             | 57 |
| Figure 5.4. ISS Ground track with coverage by just TDRS-8 (highlighted in yellow). ..                                | 58 |
| Figure 5.5. ISS Ground track with coverage by entire TDRSS.....  | 59 |
| Figure 5.6. ISS Ground track with coverage by just TDRSS with just White Sands<br>Complex (highlighted in pink)..... | 60 |

## LIST OF ABBREVIATIONS

|        |  |
|--------|--|
| AGI    | Analytical Graphics, Inc.  |
| CBS    | Cost Breakdown Structure   |
| CER    | Cost Estimating Relationship                                     |
| CONUS  | Continental United States  |
| COTS   | Commercial Off-The-Shelf   |
| DTG    | Direct to Ground   |
| ISS    | International Space Station                                      |
| Nadir  | The direction from the satellite towards the center of the earth |
| RDT&E  | Research, Development, Testing & Evaluation                      |
| Satcom | Satellite Communications   |
| STDN   | Space Tracking Data Network                                      |
| STK    | Satellite Tool Kit   |
| TDRSS  | Tracking & Data Relay Satellite System                           |
| TFU    | First Theoretical Unit   |
| TT&C   | Tracking, Telemetry & Control                                    |
| WSC    | White Sands Complex  |

## Chapter 1: Introduction

The deployment of the International Space Station (ISS) that started in November of 1998 has ushered in a new era in space exploration.[1] The ISS will provide a unique platform for research in space due to its large amount of real estate, continued presence in space, high concentration of experiments, and support from multinational government entities, organizations and companies. The platform will include a broad range of research and applications, including microgravity experiments, human physiological studies, space observation, earth observation, and much more. These functions have requirements that can be grouped into sets of similar applications requirements, including:

- Real-time video conferencing,
- Real-time monitoring and control of experiments,
- Downloading of large amounts of data (such as images), and
- On-demand access to data and experiments.

These applications requirements translate into a vast and diverse set of multimedia and data communication requirements, ranging from low to high data rates, on-demand to pre-planned, and low to high coverage. Figure 1.1 shows a sample matrix of communications requirements and applications that fall into them.

|            | Low coverage         | High coverage                  |
|------------|----------------------|--------------------------------|
| Low speed  | Monitoring & control | Low rate video, on demand data |
| High speed | Large image download | Video conferencing             |

*Figure 1.1. Sample matrix of communications requirements and applications.*

NASA is currently trying to upgrade the communication capability for commercial payloads on the ISS to enable broadband support of a variety of multimedia services.[3] NASA is also interested to gradually facilitate broadband Internet services throughout its missions, eventually leading to a scenario where every spacecraft and instrument in NASA's network can have an IP address and a connection to the Internet.[1]

Figure 1.2 shows a sample scenario of a mission satellite generating science data that is communicating with control centers and principle investigators on the ground. We assume that next generation IP-capable spacecraft would be equipped with one or more scientific instruments for specific tasks (e.g. cameras, atmospheric sensors etc.). These will have mainly one-way traffic demands (downlink of collected data) and occasional uplinks of commands or software updates. The instruments will have unique IP addresses, and would be inter-connected with an on-board Local Area Network. An IP router on-board could act as the access point to the flying network. We can therefore treat the spacecraft as a mobile platform, moving in a pre-determined orbit and accessing the NASA ground network or other Ground Stations with direct connections to the Internet.[2]

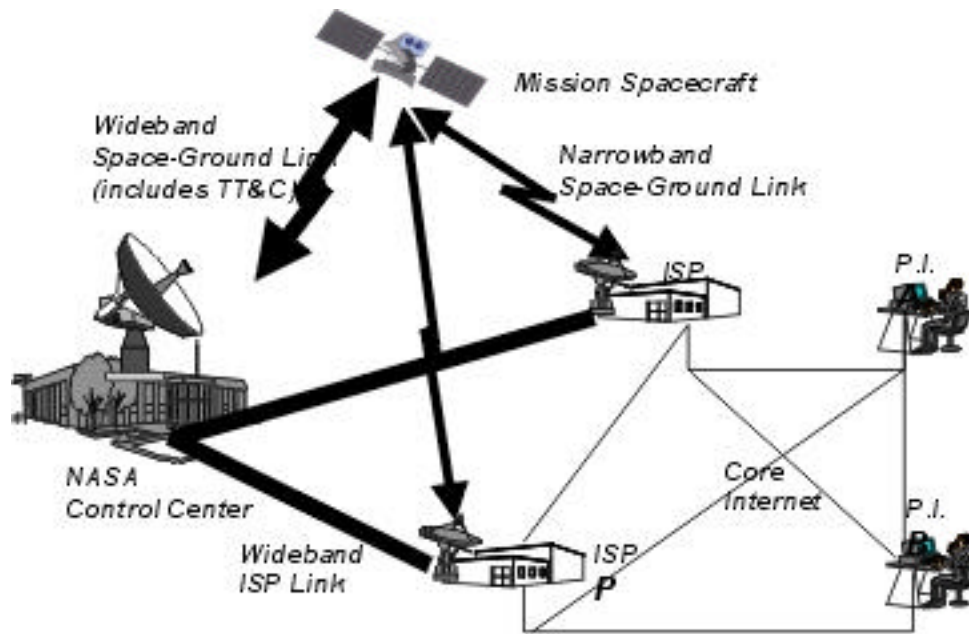

*Figure 1.2. Access methods to mission spacecraft.[2]*

There are a number of research and technology issues that need to be addressed before this scenario becomes possible. Among the most important are issues related to:

- Supporting MobileIP
- Supporting security (IPsec)
- Tracking, coverage and antenna technology
- Handover
- Traffic profiles
- Multiple access techniques and network management that allow on-demand access to space data.

## 1.1 Motivation / Significance

In order to achieve these communications services, there will be a need to provide high quality, broadband communications connectivity in order to enable cost effective global access to experimental data from the ISS and other space missions.[1] At the same time, advances in communications technology could allow investigators on Earth to enjoy a virtual presence on board the ISS. [3] However, there are limitations on the current ISS communication system and NASA's TDRSS (Tracking Data Relay Satellite System) that will not satisfy these broad communications needs in the long future. The current Ethernet onboard the ISS that provides the network backbone for services on the ISS was designed long ago, and does not have the speed necessary to support the new high-demand services. In addition, TDRSS was designed in the 1970's with initially the purpose of relaying Tracking, Telemetry, and Control (TT&C) from NASA satellites to the ground. Its services have worked well, but is becoming increasingly saturated with increased numbers of missions using its services and increased bandwidth requirements.

For these reasons, NASA is investigating alternative long-term solutions for supporting communications from ISS payloads, including the use of commercial technology and commercial assets and infrastructure in space and on the ground.[3] Gradual commercialization of space communications operations could enable:[1]

- Reduction in cost for NASA's and ESA's broadband communication needs;
- Better, faster and easier dissemination of space mission and experimental data if some of the available bandwidth and global coverage of future commercial constellations can be utilized;

- Deployment of next generation commercial satellite constellations (since space agencies might become major customers);
- Faster development in the satellite industry and also enable other commercial entities to take part in experiments and development programs in space, such as future space habitats and planetary missions.

## **1.2 Contribution of Thesis / Research**

In support of NASA's initiative in evaluating alternative solutions for ISS communications, we have started an effort to investigate the use of next generation commercial satellite constellations for supporting broadband communications for the ISS. As a first step, we have developed a simulation model for this scenario, consisting of: the ISS, models of several commercial satellite constellations, the existing NASA network and the ground network of candidate commercial constellations. This research work addresses the following topics:[1]

- Identification of potential commercial systems as candidate for investigation, starting from simple GEO (existing) Ku/Ka-band systems and moving to the next generation Ka or V band MEO / LEO systems.
- Development of a detailed simulation model that includes network architecture & topology of Hybrid Network, and in particular:
  - ISS (treated as an extremely LEO satellite) & ground network.
  - Commercial systems' constellation orbit model, ground network topology, information on routing options through constellation, Inter Satellite Links (ISLs) if any.



- Detailed simulation studies to quantify the performance of candidate satellite systems for specific services, protocols & traffic scenarios and recommend potential design modifications to ensure tele-science QoS requirements are met.

The performance parameters addressed include[1]:

***1. Coverage assessment:***

The purpose of this is to determine the maximum service time that can be made available to the ISS by the satellite constellation. (Percent of time that data could be transmitted to the ISS via the commercial satellite system - this includes Static & Dynamic coverage and the effect of Inter Satellite Links).

***2. Throughput assessment:***

Maximum daily throughput depends on the availability duration (coverage statistics) and the per-channel data rate (link quality). Simultaneous data transmission on multiple channels must also be addressed in a complete model. Again, this must be specified in the ISS requirements for sending different data to different locations, and also to multicast or broadcast data to a number of locations.

***3. Antennas & Terminals:***

Antenna & earth terminal characteristics with respect to beam size and tracking ability are considered. It would be necessary to have an antenna design well suited for covering moving satellites (in the non-GEO case) and terrestrial traffic.

Because the future of these commercial systems is uncertain and they may be years from being operational however, we may also need to investigate an interim option.

A possible solution could be the option to transmit commercial data from the ISS directly to existing commercial or NASA Ka-terminals on the ground. This is a less complex system than the commercial relay system, and may offer additional capacity to alleviate the already saturated NASA Tracking Data Relay Satellite System (TDRSS).[3]

In this report we consider three communications options: 1) using the existing NASA TDRSS, 2) using a commercial relay system, 3) communicating directly from the ISS to the ground. We will focus, however, on the direct to ground option, as it may seem a more plausible interim option than the commercial relay system. We will perform a detailed coverage and cost analysis on this option, and compare it with the other two options. The following sections will lay out these three architectures and the methodology for analyzing the options.

### **1.3 Organization of Thesis**

The three architectures for ISS communications proposed earlier will be discussed in more detail in the following chapter. A description of the current TDRSS will be provided along with comparative information on the new generation of TDRS satellites. Also, there will be a discussion of emerging commercial satellite systems and the option of the communicating direct to ground.

The third chapter provides a detailed coverage analysis of the direct to ground option, including effects of varying station minimum elevation angle and ISS antenna scan angle. Based on the findings of the analyses, a methodology for selecting the optimum placement of stations will be developed.

Using the methodology developed, Chapter 4 will provide a coverage analysis for one sample application of the ISS: large image file downloads. This will be followed in the next chapter with a detailed cost estimate of the direct to ground architecture based on the number of ground stations required from coverage analysis. The cost and coverage of the direct to ground option will also be compared with that of the TDRSS and commercial system options. Finally, the findings will be summarized in Chapter 6 along with a discussion of future work that can be done in this area.

## Chapter 2: Architectures & Methodology

There are many communications architectures available today for ISS applications. The ultimate goal is to find the optimum architecture given a certain type of setup and application. In this study we will attempt to examine the coverage and cost characteristics of our scenario for one very unique communication architecture.

The scenario we will use is that of an instrument on the International Space Station (ISS) generating data and delivering it to the ground for use by scientists. The instrument generating the data could be a video camera inside the ISS recording the astronauts or experiments, or an imaging-type camera mounted outside the ISS that collects various geographic data on the earth's surface. How the data is best transmitted to the ground is the subject of this study.

Currently, there are three main methods for transmitting data from the ISS to the ground, as shown in Figure 2.1:

1. Relaying the data through NASA's Tracking Data Relay Satellite System (TDRSS)
2. Relaying the data through a commercial broadband satellite system
3. Sending the data directly to the ground

These options will be discussed in further detail, followed by discussion of the scope and methodology of the study.

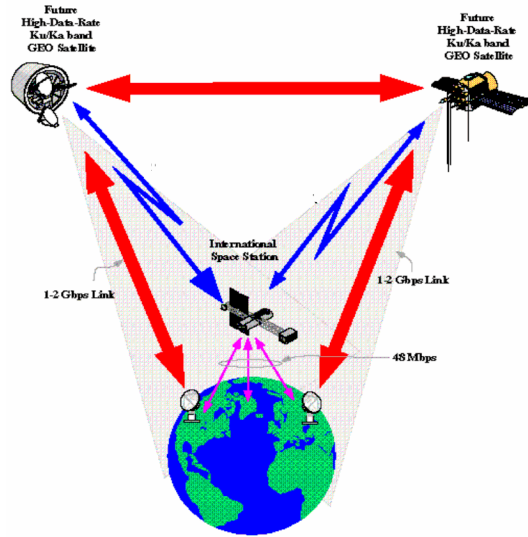

*Figure 2.1. Alternative communications architectures to/from the ISS*

## 2.1 Option 1: Using existing TDRSS

This option is the current communication infrastructure for the ISS, whereby an antenna on the ISS points upward to communicate with one of the TDRSS satellites, which relays the data to the NASA ground terminals. Figure 2.2 shows the various users and topology of the TDRS System.

The Tracking Data Relay Satellite System (TDRSS) consists of 7 satellites in geostationary orbit around the globe that relay data from satellites in Low Earth Orbit (LEO) and Medium Earth Orbit (MEO) to two ground facilities, one located at the White Sands Complex in New Mexico, and the other located at Guam. As shown in Figure 2.3, the longitudinal positions of the TDRS satellites are:

174° W, 171° W, 150° W, 49° W, 47° W, 41° W, 85° E

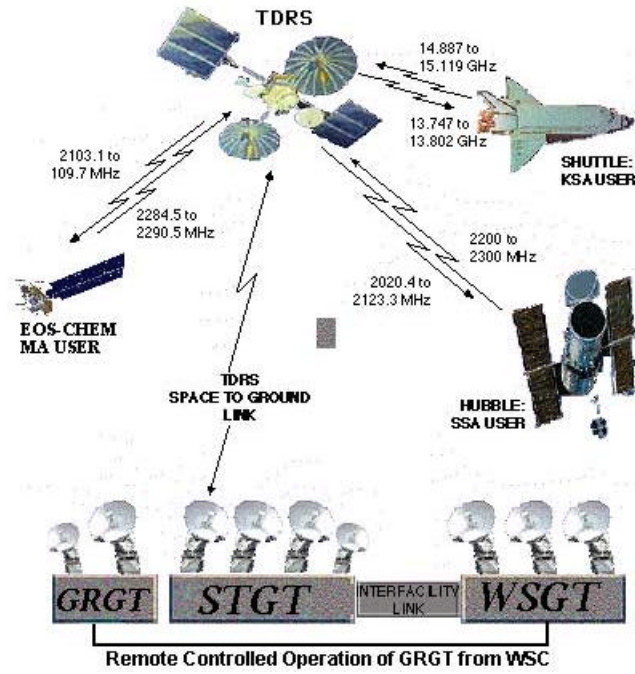

Figure 2.2. Topology of NASA TDRSS.

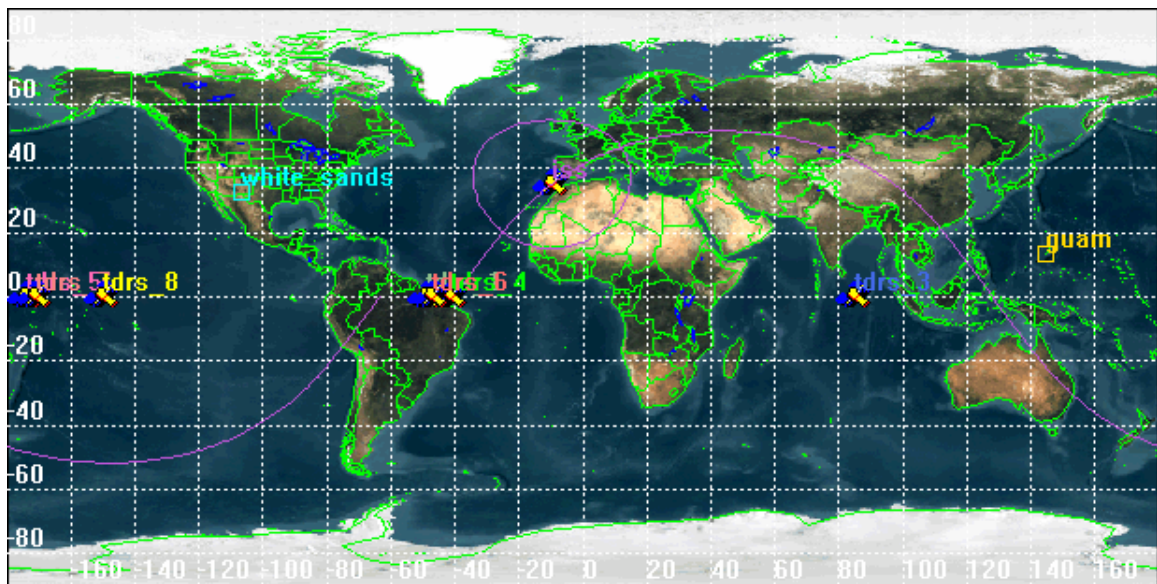

Figure 2.3. NASA TDRSS along with ISS ground track.

The TDR satellites have the capability to forward and return data in the S and Ku bands at speeds of up to 300 Mbps in the Ku band. Figure 2.4 shows the communications components of the TDRS satellites. These systems were developed in the 1970's and have been heavily used over the past two decades. A new generation of TDRS satellites (called TDRS-H, TDRS-I, and TDRS-J) has been started to augment the older system and provide additional capacity for users. The first of these satellites, TDRS-H, launched in June, 2000 and renamed TDRS-8, is positioned at -150 degrees longitude. This new generation TDRS satellite has the additional capability to relay data in Ka-band at up to 300 Mbps without modifications to the ground stations, and up to 800 Mbps with ground station modifications. A new tunable, wideband, high frequency service offered by the 15-foot antennas provides for the capability of these high data rates. This Ka-Band frequency also establishes interoperability with the international community such as the Europeans and Japanese.[4]

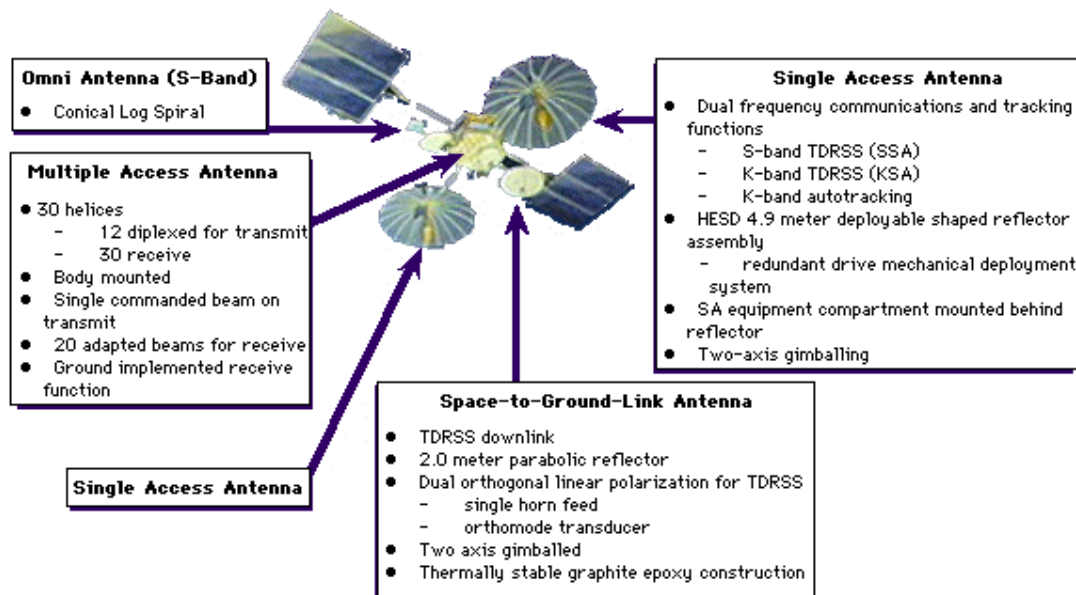

Figure 2.4. Description of TDRS antennas. [5]

Table 2.1 shows the various communications capabilities for both the (old TDRSS 1-7) and new (TDRS H, I, J). Together, the TDRS satellites provide 100% coverage for all satellites in LEO orbit, and a very reasonable transmit rate. TDRSS is currently the only system designed to relay communications for fast-moving LEO spacecraft. This makes TDRSS an excellent option to provide communications for the ISS in the long-term future.

|                   | Service  | TDRSS 1-7       |                       | TDRS-H,I,J                   | Notes  |
|-------------------|--|-----------------|-----------------------|------------------------------|--|
| Single Access     | S-Band   | FWD             | 300 kbps              | 300 kbps                     | No change  |
|                   |  | RTN             | 6Mbps                 | 6Mbps                        |  |
|                   | Ku-Band  | FWD             | 25 Mbps               | 25 Mbps**                    | No change  |
|                   |  | RTN             | 300 Mbps              | 300 Mbps                     |  |
|                   | Ka-Band  | FWD             | N/A                   | 25 Mbps**                    | 23/25-27 GHz frequency band  |
|                   |  | RTN             | N/A                   | 800 Mbps*                    |  |
|                   | Number of Links per Spacecraft                 | 2 SSA<br>2 KuSA |                       | 2 SSA<br>2 KuSA<br>2 KaSA    | For TDRS-H,I,J simultaneous operation of S & Ku and S & Ka services a single SA antenna are required |
|                   | Number of Multiple Access Links per Spacecraft | FWD             | 1@10 kbps             | 1@300 kbps (8 dB over TDRSS) | Anticipated SSA users less than 3 Mbps offloaded to TDRS-H,I,J MA                                    |
| RTN               |  | 5@100 kbps      | 5 @ 3 Mbps            |                              |  |
| Customer Tracking | 150 meters<br>3 sigma                          |                 | 150 meters<br>3 sigma | No change                    |  |

**Table 2.1. Comparison of current and new TDRSS services. [6]**

Although this system has excellent coverage, its system capacity is being used to its maximum. In addition, there are currently limitations on the main ISS Access Communication System that provides the link to the TDRSS. The limitations of the current system are noted below:



- The current design of the ISS high-rate Ku-Band uses NASA proprietary components, making any future communication system expensive and difficult to implement in a short turn-around time.
- Limitations in the current NASA ground network connectivity means that high rate global data dissemination could face significant limitations.
- Many commercial users will need commercially supported broadband communications.

For all these reasons it makes sense to adopt a new uniform architecture that is based on commercial standards to support future commercial services. An independent contractor conducted a study for NASA in 1995 to determine the commercial interest and capability of providing TDRS-like services to NASA in lieu of building TDRS-H, I, J. The study at the time revealed little commercial interest, and no single system in development could provide such services until at least 2005.[7]

## **2.2 Option 2: Using commercial satellite systems as relay**

This option essentially means using a commercial fleet of satellites as in lieu of using the TDRSS. There are many Ka-band satellite communication systems that are planned to be deployed within the next few years that provide services such as voice, data, video broadcasting, and many others. Table 2.2 shows a listing of some of these commercial systems planning to transmit data in Ka-band and other bands. This option could be a later solution, as there are currently no commercial systems operating at these frequencies that can communicate with moving assets in space. However, if potential interest develops, satellite companies could add a payload to future system expansions

that could do that and then offer the relay-to-ground option as a service to NASA or other paying customers.

| Satellite System | Country of Origin | Backer(s)       | Num. of Satellites proposed | Orbit Type | Coverage Region | Satellite Capacity (Gbps) | System Setup |
|------------------|-------------------|-----------------|-----------------------------|------------|-----------------|---------------------------|--------------|
| Astrolink        | USA               | Lockheed Martin | 9                           | GSO        | global          | 6.5                       | 2002-2003    |
| Cyberstar        | USA               | Loral Space     | 3                           | GSO        | multiregional   | 4.9                       | 1998-2001    |
| Echostar         | USA               | Echostar        | 2                           | GSO        | USA             | 5.8                       |              |
| Euroskyway       | Italy             | Alenia Spazio   | 5                           | GSO        | Europe          | 8                         | 2003         |
| Eutelsat K       | Regional, Europe  | Eutelsat        | 23                          | GSO        |                 |                           |              |
| Inmarsat         | International     | PTTs            | 6                           | GSO        |                 |                           |              |
| Intelsat         | International     | PTTs            | 12                          | GSO        |                 |                           |              |
| ISky (Ka-Star)   | USA               | Private         | 2                           | GSO        | USA             | 7.5                       | 2001-2002    |
| Orion            | USA               | Orion           | 6                           | GSO        |                 |                           |              |
| PanAmSat         | USA               | Hughes          | 1                           | GSO        |                 |                           |              |
| SkyBridge        | France/USA        | Alcatel         | 80                          | LEO        | global          | 1 Gb/s per beam           | 2001-2002    |
| Spaceway         | USA               | Hughes          | 8                           | GSO        | global          | 4.4                       | 2002-2003    |
| Teledesic        | USA               | Gates / McCaw   | 288                         | LEO        | global          | 10                        | 2004         |
| Videosat         | France            | France Telecom  | 3                           | GSO        |                 |                           |              |
| Vision Star      | USA               |                 | 1                           | GSO        | CONUS           | 1.9                       | 2002-2005    |

*Table 2.2. Emerging Ka-band commercial satellite systems. [8],[9]*

The intended customers of these services, however, are generally businesses and in some cases, home consumers, not a NASA spacecraft moving in a LEO orbit. Thus, usage of these systems as a relay may not be optimum for the needs of the ISS. These systems will likely be using multiple spot beam antennas pointed towards populated areas of the earth, received by either fixed antennas or slow-moving users. Its ability to maintain communications with the ISS traveling at over 17,000 Mph (27,000 Kph) at about 230 miles (400 km) flying through its hundreds of spot beams may be limited.

Coverage is not likely to be nearly as good as that provided by TDRSS, and commercial prices charged by these service providers may be expensive.

### **2.3 Option 3: ISS direct to Ka-band ground terminals**

Instead of relaying data through commercial assets in space, the ISS could send the data directly to the ground terminals of satellite companies planning to deploy Ka-band satellite systems. The ground networks could be used as access points for downloading ISS data from the ISS Direct-to-Ground (DTG). However, these commercial satellites, as discussed earlier, are generally placed in geostationary orbit for simplicity and to allow customers to downlink from the satellites without having to track the satellites. This means, though, that the ground stations will be comprised of ground terminals that are not capable of tracking, and instead fixed to point towards specific stationary satellites. Fixed terminals will not be able to track a fast-moving satellite such as the ISS. Due to the possible limited tracking capability, the coverage these terminals provide to a rapidly moving LEO spacecraft might not be sufficient, and there might be a need to either add tracking capability to these terminals or augment the coverage by adding additional terminals distributed globally. The latter is not a likely option considering it would not be an effective cost trade-off.

Thus, because it is uncertain when these commercial systems will actually be realized, new fixed Ka-band terminals could be added to existing NASA ground facilities that are already distributed throughout the globe. These terminals would have tracking capability, and only incur the incremental cost of additional staff and equipment since

they would be located at existing facilities. In addition, communications infrastructure on these ground facilities are already in place at these NASA facilities.

## **2.4 Methodology & Scope**

In review of these options, we find that the current option of using TDRSS has limitations that do not satisfy requirements of some future customers. The option of relaying data over commercial in-space assets is a long-term and uncertain one. In addition, while the option of communicating directly to future commercial ground stations may be a good interim solution, the best may be to consider using NASA's existing ground facilities, which is where we will focus on in this report.

We will evaluate the feasibility of using existing NASA facilities augmented with Ka-band terminals for ISS communications in the near future, and discuss this option versus using TDRSS and a commercial relay constellation. We will limit discussion of the options to a high-level systems engineering analysis that will not consider the details of communications protocol-related issues such as mobility support, QoS support, multiple access, multiplexing, and error control. Included in this study will be 1) a detailed analysis on the coverage obtained by the ISS to various assets on the ground and in space, and 2) a bottom-up cost estimate of the direct to ground option.

The first step in evaluating the ISS Direct to Ground architecture is to understand the effect of the distribution of the ground stations on coverage. Several simulation scenarios will be developed using the satellite orbit analysis tool Satellite Tool Kit by Analytical Graphics, Inc. (AGI) consisting of the ISS, NASA ground stations, antennas, TDRS satellites, and commercial satellites.

We will study the coverage for stations placed at constant longitude and varying latitude, and compare that with stations distributed at random longitudes. From this study we will understand the proper latitude or longitudes for placing the ground stations to get the maximum coverage with the fewest number of stations. We will then move on to analyze the effect of changing the minimum elevation angle of the ground stations and the scan angle of the ISS main downlink antenna. For simplicity at this stage, a phased array antenna on the ISS used for Direct-to-Ground communication will be modeled as a simple cone with varying half cone angles to simulate the scan angle of the phased array antenna. The resulting coverage due to the varying minimum elevation and cone angles will yield patterns that may be helpful in choosing the proper angles. We will also briefly discuss sensitivity of these angles at various ground station latitude positions to understand how relaxing or stiffening the constraints may affect the resulting coverage.

In order to select the proper ground stations to receive the ISS data, a methodology will be developed using information gained from the coverage analysis. From a database of NASA ground facilities, ground stations located at the optimal latitudes or longitudes will first be selected. Then, additional stations will be selected that provide complementary coverage with minimal overlap. Access from the ISS antenna will be computed to the ground stations, and the stations will be ranked in order of decreasing total access durations. The cumulative total access times of these stations will be calculated along with the total daily throughput in megabits per second. This will allow someone desiring a certain throughput to get an initial estimate of the number of stations that will be needed to satisfy the coverage requirement, and select only the stations with the best coverage. This data assumes independent non-overlapping

coverage areas, and may double-count contacts where there is line of sight to more than one station.

The next step is to group these stations together into what is called a “constellation” in Satellite Tool Kit, and create a “chain” from the ISS antenna to the constellation of ground stations. This will eliminate possible double-counting and generate contacts only to one station at a time. Generating a chain this way will show the total amount of coverage when the ISS antenna has access to any one station in the constellation at a time. The actual amount of coverage obtained in units of seconds per day will be translated into throughput for three representative transmit rates. A sample application will be selected and a coverage analysis will be performed for this application.

After the coverage analysis is complete, a cost estimate for the direct to ground system will be computed using a bottom-up method. Costs will be calculated for various elements in the cost breakdown structure of the system. Only the communications components that vary between the three architectures will be considered. A combination of costing methods including direct estimation, analogy, and parametric cost estimation will be used. The cost, coverage, and throughput for this system will then be compared to the TDRSS and commercial broadband satellite relay system.

## Chapter 3: Coverage Analysis

A simulation of the ISS communicating to ground stations was developed using Satellite Tool Kit version 4.2. Included in the simulation were the ISS, the downlink antenna on the ISS, and selected NASA ground stations around the world. Access from the ISS antenna to the ground stations was calculated for various scenarios.

A scenario was first created with a run time of 10 days in order to minimize aberrations in results due to differing diurnal orbit characteristics. Running the simulation, for just one day, for example, could yield different results depending on where the longitude of ascending node of the satellite's orbit is placed since the satellite does not have sufficient time to cover all areas of the globe within one day.

The orbit of the ISS used in the simulation models the characteristics of the real ISS's current orbit. Following are the parameters for the ISS model's orbit:

Eccentricity: 0 (i.e., circular orbit)

Altitude: 400 km

Inclination:  $51.5^\circ$

### 3.1 Effect of Longitude & Latitude of Stations on Coverage

In order to understand the effect of the placement of the ground stations' location on the coverage provided by the ISS, the latitude and longitude of the stations are varied. An analysis on the effect of the stations' latitudinal placement was first studied by placing stations at arbitrary latitudinal positions along the zero-longitude line.

Stations were placed at 15-degree intervals above and below the equator starting at 0 degrees latitude until  $\pm 30$  degrees, where stations were placed at closer increments (5 degrees) to provide better resolution. Near the ISS's orbit, stations were placed at 5-degree increments above and below its inclination of 51.5 degrees. Figure 3.1 shows the graphical placement of the ground stations, along with the ISS ground track. The circle around the ISS is the projection of the ISS main antenna onto the surface of the earth, representing the area on the earth that has contact with the ISS. Following is the placement of all the 27 ground stations:

0,  $\pm 15$ ,  $\pm 30$ ,  $\pm 35$ ,  $\pm 40$ ,  $\pm 45$ ,  $\pm 49.5$ ,  $\pm 51.5$ ,  $\pm 56.5$ ,  $\pm 61.5$ ,  $\pm 65$ ,  $\pm 70$ ,  $\pm 75$ ,  $\pm 90$ .

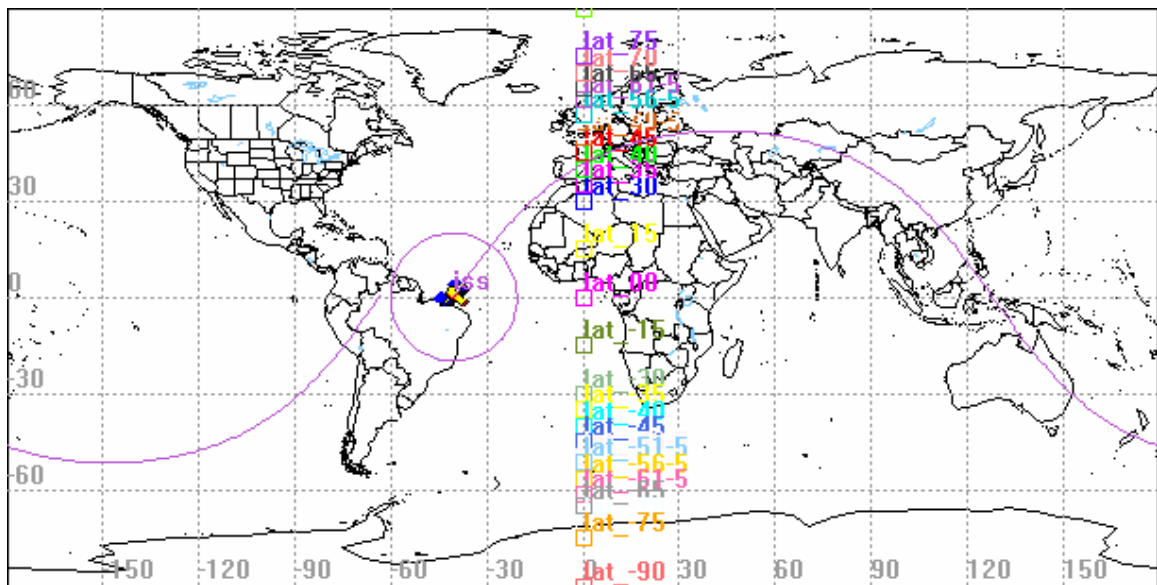
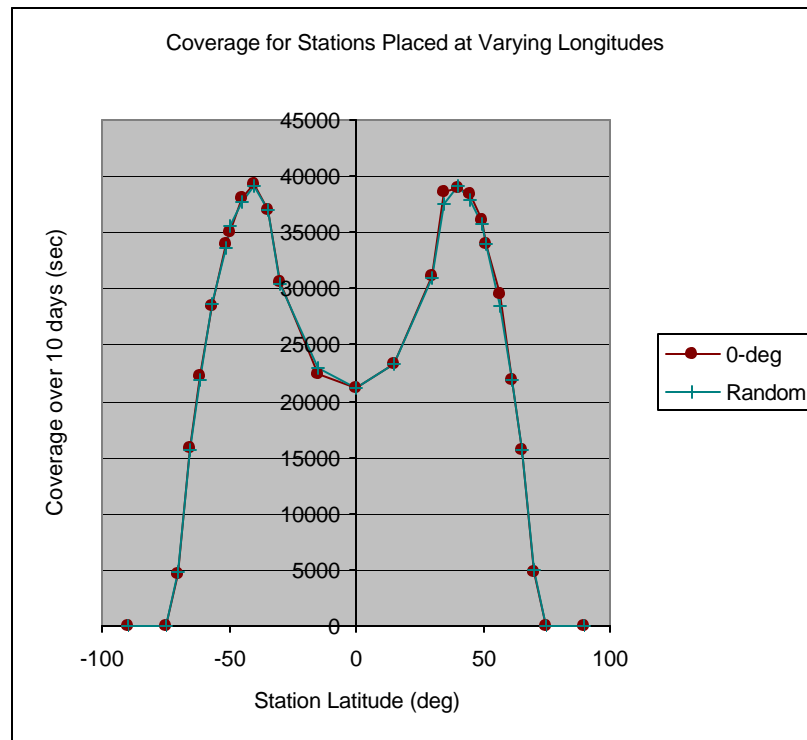

*Figure 3.1. Distribution of stations at 0-longitude and varying latitudes.*

The stations were assumed to have zero-degree minimum elevation angles and the ISS onboard antenna was assumed to have a cone angle of 90 degrees in order to provide full field of view. Figure 3.2 shows the distribution of the coverage for the ground stations as a result of running the scenario over a 10-day period. It is interesting to



observe that the coverage is not constant for all the ground stations, but peaks at locations near the inclination angle of the satellite. In this case, the ISS inclination angle is 51.5 degrees, and the station that has the most coverage is the one placed at  $\pm 40$  degrees latitude. The coverage drops off dramatically for stations placed above the inclination angle, and becomes zero for stations placed at  $\pm 75$  latitude and higher.



**Figure 3.2. Coverage over 10 days for varying station latitude.**

A second analysis was performed by distributing the ground stations at arbitrary longitude positions around the globe, as shown in Figure 3.3. The location of the stations were chosen to provide variation in the longitude of the stations at both low and high latitudes. The results from the simulation show that the coverage is essentially identical to that achieved when the stations were all placed along the 0-degree longitude. In fact, the correlation between the coverage data of the two scenarios was 0.999664. This

indicates that the coverage achieved by a station is dependent only on its latitude position and not its longitude. We will take advantage of this independence and continue the upcoming simulations for stations placed at 0-degree longitude.

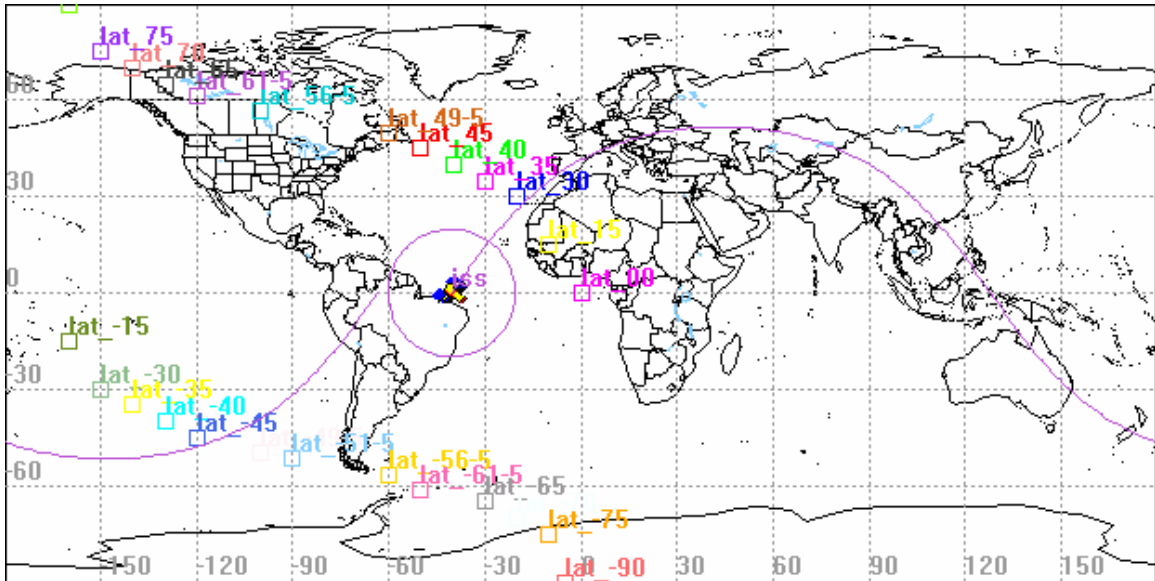
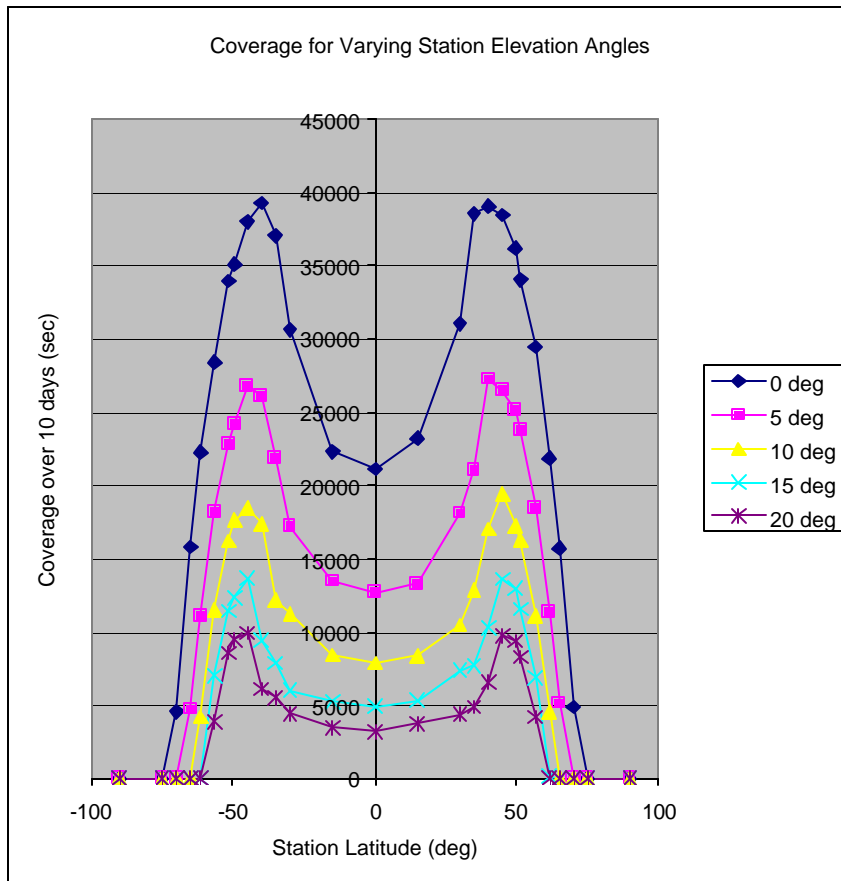

*Figure 3.3. Distribution of stations at arbitrary longitudes.*

### **3.2 Effect of station Elevation angle on coverage**

To understand the effect of the ground stations' minimum elevation angle on coverage, we place ground stations along the zero-longitude line, and vary the minimum elevation angle starting from zero. The minimum elevation angle is defined as the angle between the local horizon of the station and the line of sight to the ISS. Local terrain or buildings may block a station's line of sight to the satellite, resulting in higher minimum elevation angles. Zero-degree minimum elevation angle means that there are no obstructions, and the station has complete full field of view to the satellite.

For this scenario, the minimum elevation angle was varied for all of the 27 stations between 0 degrees and 20 degrees. The ISS main antenna was assumed to have full field of view, or a cone half angle of 90 degrees to provide the maximum coverage possible. Coverage for each of the 27 ground stations was calculated for each minimum elevation angle, resulting in a series of curves shown in Figure 3.4.

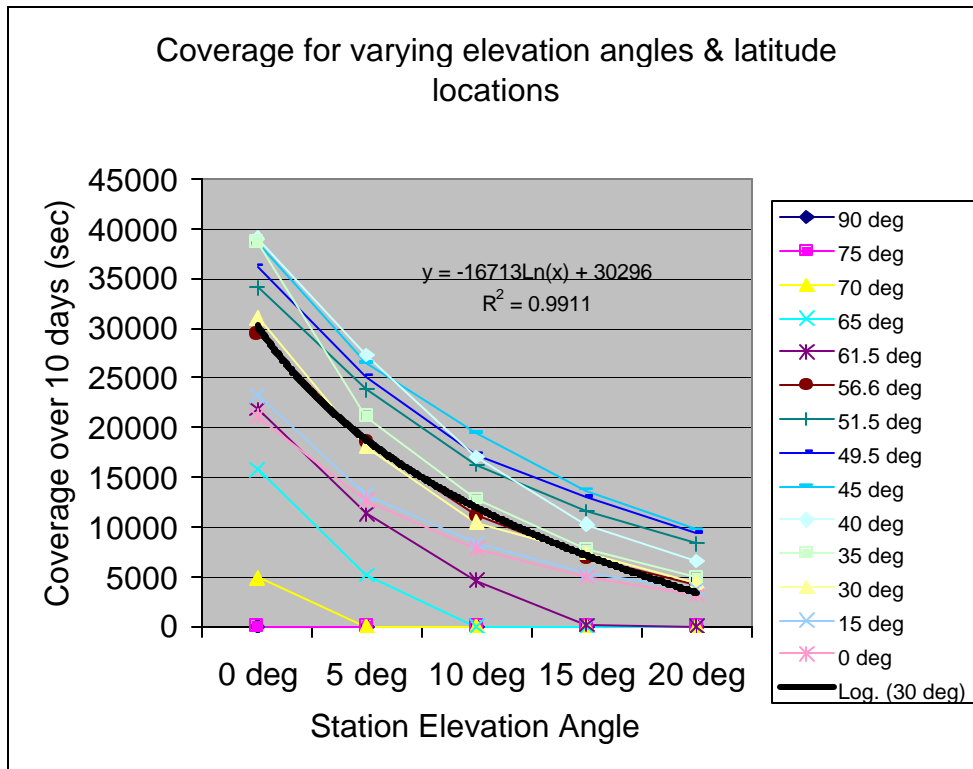

**Figure 3.4.** Coverage with respect to station latitude for varying min. elevation angles.

By looking at the graph, we can see that the coverage is almost uniformly reduced at each station as the elevation angle is increased. It is also interesting to observe that the location of the peak coverage increases slightly as the minimum elevation is increased.

This is because as the field of view of the station is reduced, the station must be placed closer to the satellite's inclination in order to provide a more local north (perpendicular) contact under the satellite.

Figure 3.5, shows the plot of the coverage with respect to the elevation angles. A regression of one of the curves, that pertaining to facilities placed at 30 degrees latitude, shows that the coverage is approximately a logarithmic relationship with respect to minimum elevation angle.



**Figure 3.5. Coverage with respect to station minimum elevation angle.**

To understand the sensitivity of the elevation angles to coverage, we observe the unit change in the elevation angle to the resulting unit change in coverage.[10] The

slopes of the curves are higher at lower elevation angles, indicating that the coverage is more sensitive at lower minimum elevation angles than at higher minimum elevation angles.

### **3.3 Effect of ISS antenna scan angle on coverage**

To understand the effect of the ISS onboard antenna's scan angle on coverage, we fix the locations of the ground stations, and vary the scan angle on the ISS antenna. The antenna actually onboard the ISS would likely be a phased array antenna, with a certain ability to scan from one edge to the other. In the scenario, the antenna is modeled as a simple cone pointing nadir (towards the center of the earth), and the cone half-angle, or scan angle, is defined as the angle between the vector connecting the center of the antenna to the ground station (the boresight) and the outermost edge of the antenna. A small scan angle would be representative of a pencil beam, while a scan angle of 90 degrees represents full field of view, or the capability of the phased array antenna to scan completely from one side of the local horizon to the other.

For this scenario, the ISS antenna is varied from 30 degrees to 90 degrees, while the minimum elevation angle for all of the stations are kept at zero to achieve the maximum possible coverage. The stations are placed along the zero longitude line. Coverage for each of the 27 ground stations was calculated over 10 days for each antenna cone angle, resulting in the series of curves shown in Figure 3.6.

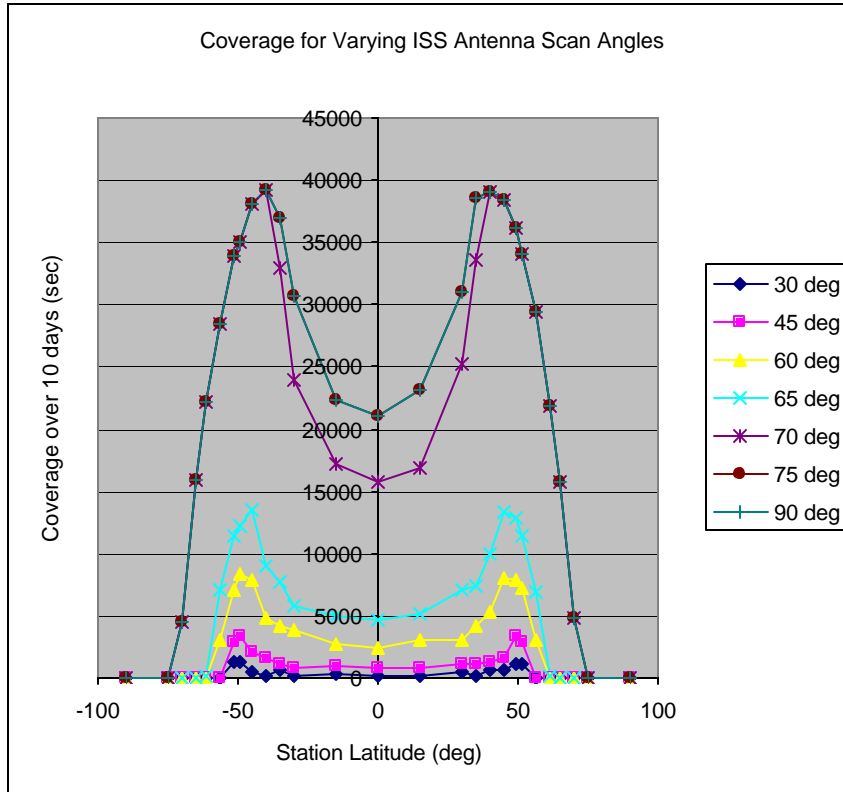

**Figure 3.6. Coverage with respect to latitude for varying ISS antenna scan angles.**

Coverage for cone angle of 75 degrees is the same as that for 90 degrees, indicating that the best coverage can be achieved even when the cone angle is only 75 degrees. This is a result of the curvature of the earth and the satellite’s altitude. As the satellite is moved further from the earth, it can see more of the earth with a smaller field of view. Satellites that are closer to the earth, such as the ISS, have a maximum field of field that is near 75 degrees.

In addition, the coverage drops off significantly when the cone angle is decreased slightly after 70 degrees, and quickly approaches zero as the cone angle approaches zero. The plot in Figure 3.7 of coverage as a function of ISS cone angle for stations at various latitudes shows that the ISS antenna cone angle has a very non-linear affect on coverage.

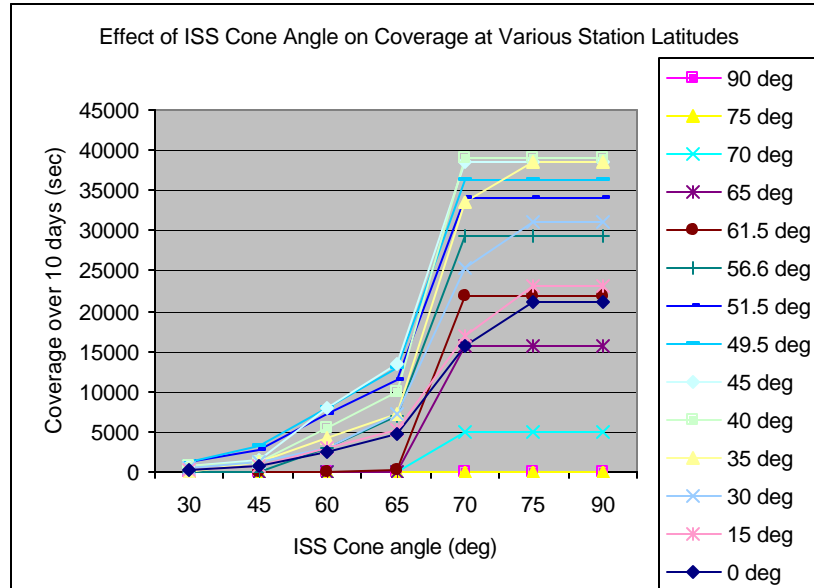

**Figure 3.7. Coverage with respect to ISS cone angle.**

As can be seen, there is greater sensitivity when the ISS cone angle is large as compared to when it is small. This indicates that there is significant gain in coverage per degree change in cone angle when the cone angle is near 70 degrees. In addition, the coverage reaches its maximum and becomes flat sharply near 70 degrees, but maintains a smooth function all the way up to 90 degrees.

Closer inspection of the graph and the data in Table 3.1 reveals that between 67 degrees and zero degrees cone angle, the curves do not approach the origin, but rather reach zero at some  $\theta_i$  as the cone angle decreases, and stays flat.

| Station Latitude | ISS Cone half angle |          |          |           |           |           |           |
|------------------|---------------------|----------|----------|-----------|-----------|-----------|-----------|
|                  | 30                  | 45       | 60       | 65        | 70        | 75        | 90        |
| 90 deg           | 0                   | 0        | 0        | 0         | 0         | 0         | 0         |
| 75 deg           | 0                   | 0        | 0        | 0         | 0         | 0         | 0         |
| 70 deg           | 0                   | 0        | 0        | 0         | 4889.239  | 4889.239  | 4889.239  |
| 65 deg           | 0                   | 0        | 0        | 0         | 15734.835 | 15734.835 | 15734.835 |
| 61.5 deg         | 0                   | 0        | 0        | 214.308   | 21862.414 | 21862.414 | 21862.414 |
| 56.6 deg         | 0                   | 0        | 3031.618 | 6911.167  | 29444.629 | 29444.629 | 29444.629 |
| 51.5 deg         | 1128.17             | 2834.367 | 7295.993 | 11490.743 | 34037.55  | 34037.55  | 34037.55  |
| 49.5 deg         | 1171.169            | 3329.736 | 7934.023 | 12858.526 | 36174.237 | 36174.237 | 36174.237 |
| 45 deg           | 661.925             | 1602.98  | 8076.67  | 13403.021 | 38460.334 | 38460.334 | 38460.334 |
| 40 deg           | 715.048             | 1321.708 | 5352.829 | 9983.831  | 39029.335 | 39029.335 | 39029.335 |
| 35 deg           | 121.776             | 1165.06  | 4238.435 | 7327.002  | 33665.097 | 38560.561 | 38560.561 |
| 30 deg           | 518.856             | 1138.767 | 3031.624 | 7128.089  | 25236.443 | 31043.453 | 31043.453 |
| 15 deg           | 160.542             | 780.425  | 2984.321 | 5144.673  | 16907.901 | 23213.558 | 23213.558 |
| 0 deg            | 178.78              | 779.568  | 2434.788 | 4716.956  | 15700.223 | 21129.121 | 21129.121 |

**Table 3.1. Coverage data for varying station latitude and ISS cone angles.**

### 3.4 Effect of station elevation angle and ISS antenna scan angle

In this section we examine the variation of coverage with respect to both the ground stations' minimum elevation angle and the ISS antenna half cone angle. One station was chosen for this analysis – the station at 0 degrees longitude and 0 degrees latitude, while its minimum elevation angle was varied from 0 to 30 and the ISS antenna cone angle was varied from 30 to 90.

|                 |    | ISS main antenna half cone angle (deg) |         |          |          |           |           |           |
|-----------------|----|--|---------|----------|----------|-----------|-----------|-----------|
|                 |    | 30                                     | 45      | 60       | 65       | 70        | 75        | 90        |
| Elevation Angle | 0  | 178.78                                 | 779.568 | 2434.788 | 4716.956 | 15700.223 | 21129.121 | 21129.121 |
|                 | 5  | 178.78                                 | 779.568 | 2434.788 | 4716.956 | 12706.666 | 12706.666 | 12706.666 |
|                 | 10 | 178.78                                 | 779.568 | 2434.788 | 4716.956 | 7874.702  | 7874.702  | 7874.702  |
|                 | 15 | 178.78                                 | 779.568 | 2434.788 | 4716.956 | 4938.603  | 4938.603  | 4938.603  |
|                 | 20 | 178.78                                 | 779.568 | 2434.788 | 3191.709 | 3191.709  | 3191.709  | 3191.709  |
|                 | 25 | 178.78                                 | 779.568 | 2077.643 | 2077.643 | 2077.643  | 2077.643  | 2077.643  |
|                 | 30 | 178.78                                 | 779.568 | 1508.371 | 1508.371 | 1508.371  | 1508.371  | 1508.371  |

**Table 3.2. Coverage data for varying elevation angle and cone angle.**

As can be seen from the Table 3.2 and Figure 3.8, there are areas where the coverage is constant for certain elevation angles and ISS cone angles. In general, for a



particular minimum station elevation angle,  $\epsilon$ , the coverage is constant (unaffected by the ISS cone angle,  $\alpha$ ) until the cone angle is considerably smaller than the complement of the elevation angle,  $90^\circ - \epsilon$ . This is due to the geometry of the ISS antenna and the station as the ISS approaches the station and makes a contact within each other's field of view. In addition, for a particular cone angle, the coverage is constant (unaffected by the elevation angle), until the elevation angle is nearly greater than the complement of the cone angle,  $90^\circ - \alpha$ . A line can thus be imagined in the Table above that acts as the boundary between changing and non-changing coverage for various minimum elevation angles and cone angles. Thus, knowing this, we can freely adjust the ISS cone angle and ground station minimum elevation angles for configurations where one does not affect the other.

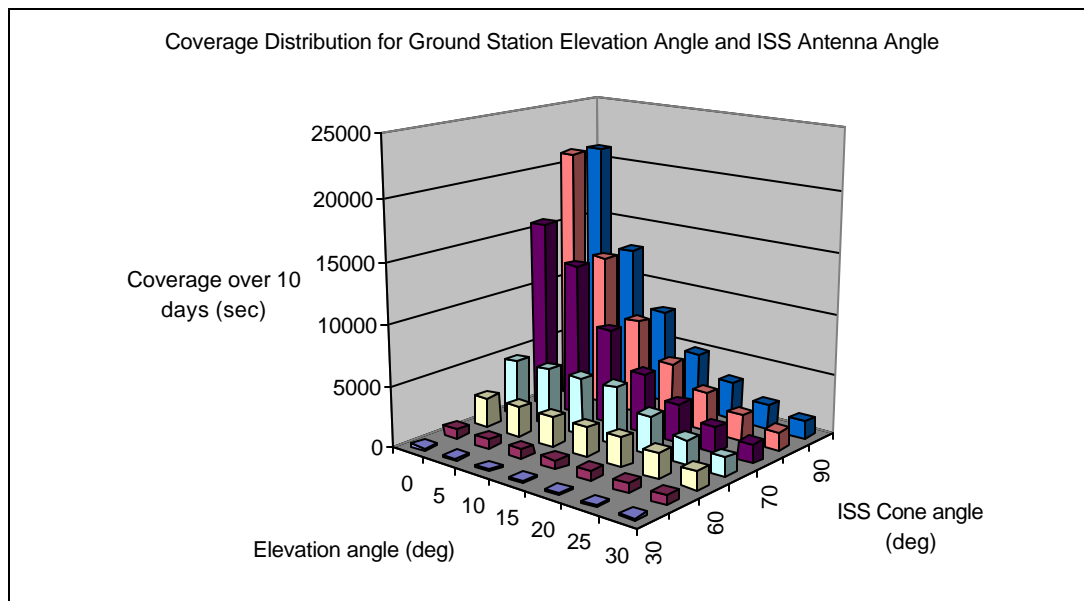

**Figure 3.8. Coverage for varying elevation angle and cone angle.**

### 3.5 Coverage with Select Ground Stations

The information learned from the coverage simulations of multiple elevation angles and antenna cone angles can be used to determine placement of ground stations for optimal coverage with the ISS. In this section, we will determine the coverage available with existing NASA ground facilities throughout the world. These facilities are contained in databases provided with the Satellite Tool Kit software.

For all the ground stations, we will set a minimum elevation angle of 10 degrees, which is a nominal angle for many NASA ground stations. In the first scenario, the ISS antenna scan angle will be set to the angle that provides the maximum coverage for this satellite orbit: 75 degrees.

Knowing prior simulations that we achieve the greatest coverage for stations near 40 degrees latitude, the strategy will be to first select NASA ground facilities that are close to  $\pm 40$  degrees latitude. The minimum elevation angle of 10 degrees is set for the stations, and access is computed from the ISS antenna to each of these initial stations. Figure 3.9 shows the coverage of these 5 initial stations, each with its individual color. The bold lines around each facility represent the portion of the ISS orbit throughout the 10 days where the ISS antenna is in view of the ground station below.

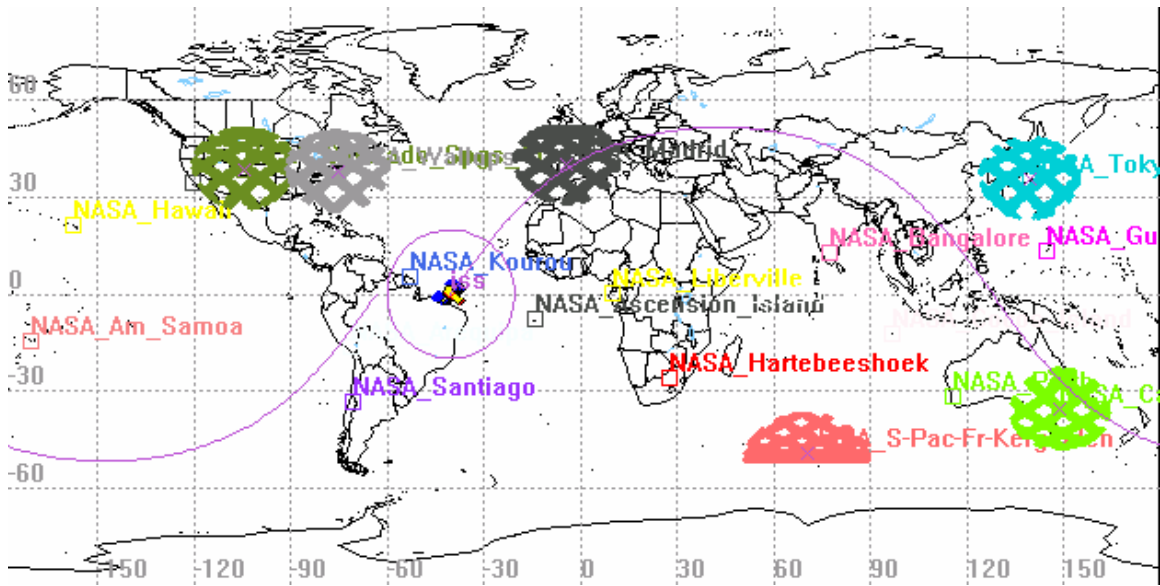

**Figure 3.9.** Selected NASA ground stations at high latitudes shown with access circles.

With these stations in place, we can see graphically where there are open areas of coverage, and select additional NASA ground stations that provide additional coverage as close to the initial ones as possible without much overlap. This step is repeated until all the NASA ground stations of interest are identified.

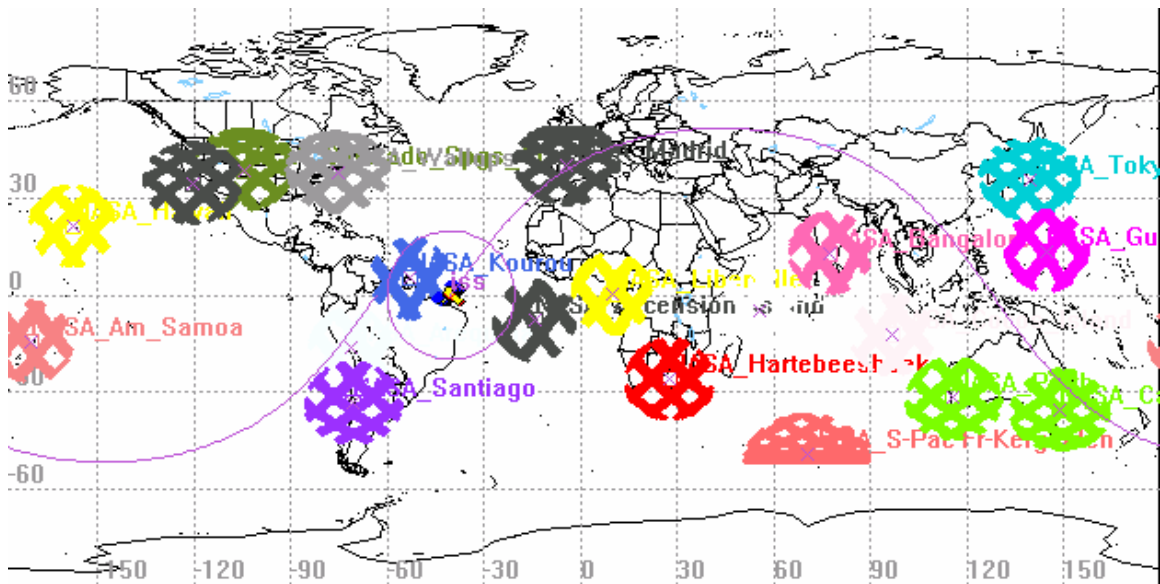
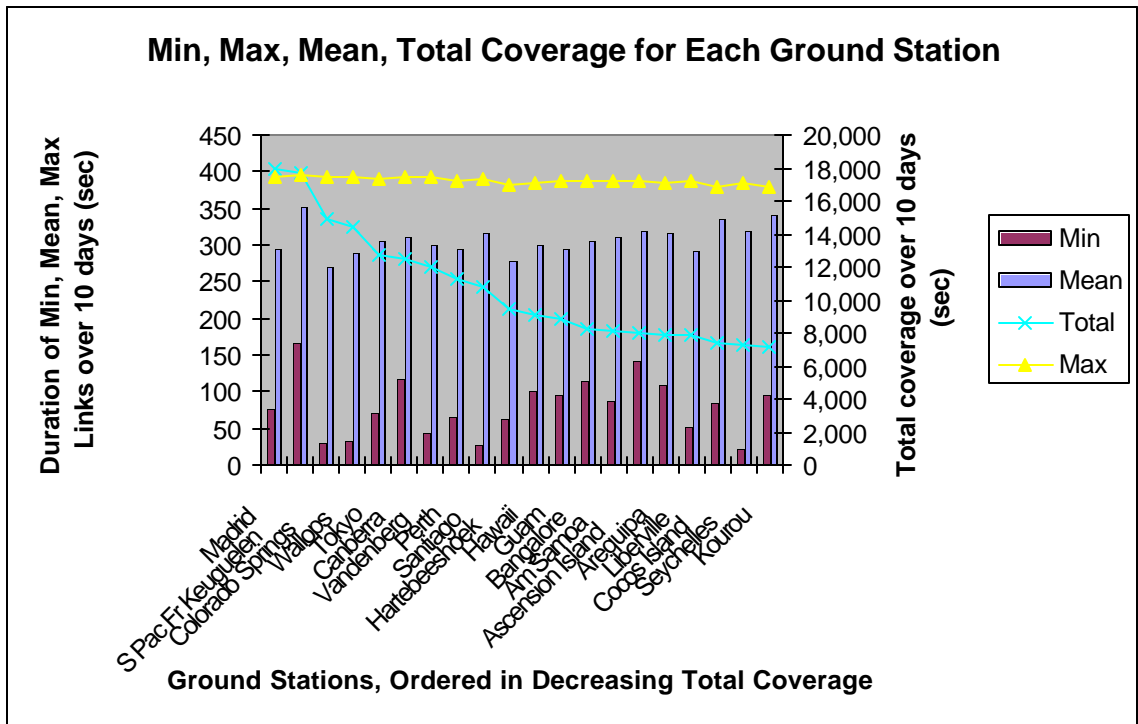

**Figure 3.10.** Selection of 20 NASA ground stations for 75 deg scan angle.

Figure 3.10 shows the setup of the 20 ground stations chosen and their coverage. Throughout the 10 days simulated, the ISS will have many contacts or “links” with each ground station facility. Of interest to observe is the duration of each link. In particular, for each station, data is obtained for the duration of the shortest link, the longest link, and the mean duration of all links. In addition, the duration of all links for each station is summed as the “total” coverage for each station. The ground stations are then ordered in decreasing total coverage. In addition, Table 3.3 shows these results in a tabular format, ranked by total coverage. As expected from the studies performed earlier, the stations with the higher total coverage also had higher latitudes, so the ordering of ground station in Figure 3.11 also roughly corresponds to decreasing station latitude.

|                    | # Contacts | Min    | Mean   | Max    | Total     | Lat (Abs) | Lat (deg) |
|--------------------|------------|--------|--------|--------|-----------|-----------|-----------|
| Madrid             | 61         | 77.05  | 294.59 | 393.73 | 17,969.94 | 40.43     | 40.43     |
| S Pac Fr Keuguelen | 50         | 167.42 | 353.04 | 396.82 | 17,651.89 | 49.35     | -49.35    |
| Colorado Springs   | 55         | 29.04  | 269.99 | 392.56 | 14,849.46 | 38.81     | 38.81     |
| Wallops            | 50         | 33.99  | 288.95 | 393.56 | 14,447.23 | 37.95     | 37.95     |
| Tokyo              | 42         | 69.62  | 304.31 | 389.47 | 12,780.92 | 35.71     | 35.71     |
| Canberra           | 40         | 117.52 | 311.13 | 392.51 | 12,445.32 | 35.41     | -35.41    |
| Vandenberg         | 40         | 44.81  | 299.49 | 392.30 | 11,979.55 | 34.58     | 34.58     |
| Perth              | 38         | 64.37  | 295.30 | 387.36 | 11,221.19 | 31.80     | -31.80    |
| Santiago           | 34         | 28.53  | 315.72 | 390.16 | 10,734.49 | 33.15     | -33.15    |
| Hartebeeshoek      | 34         | 62.12  | 278.92 | 382.11 | 9,483.24  | 25.89     | -25.89    |
| Hawaii             | 30         | 101.99 | 301.23 | 385.36 | 9,036.74  | 21.32     | 21.32     |
| Guam               | 30         | 96.37  | 294.23 | 388.34 | 8,826.74  | 13.62     | 13.62     |
| Bangalore          | 27         | 114.87 | 305.16 | 387.38 | 8,239.37  | 13.03     | 13.03     |
| Am Samoa           | 26         | 87.34  | 311.64 | 388.08 | 8,102.67  | 14.33     | -14.33    |
| Ascension Island   | 25         | 142.99 | 317.73 | 387.82 | 7,943.29  | 7.92      | -7.92     |
| Arequipa           | 25         | 108.36 | 316.41 | 385.34 | 7,910.21  | 16.47     | -16.47    |
| Liberville         | 27         | 53.03  | 292.93 | 387.52 | 7,909.06  | 0.36      | 0.36      |
| Cocos Island       | 22         | 85.19  | 336.00 | 378.79 | 7,392.06  | 12.20     | -12.20    |
| Seychelles         | 23         | 23.09  | 318.54 | 383.32 | 7,326.34  | 4.67      | -4.67     |
| Kourou             | 21         | 96.56  | 341.68 | 377.83 | 7,175.17  | 5.21      | 5.21      |

**Table 3.3. Coverage provided by each of the 20 selected ground stations.**



*Figure 3.11. Min, Max, Mean Total coverage for selected ground stations.*

We observe that the minimum durations for the links are rather random and have no correlation to the latitude of the stations. The mean duration is less variable, but no definitive relationship can be made between that and the station latitude. The maximum duration remains rather constant, or perhaps decreases slightly, for all station latitude locations. The total coverage of all links for each station decreases correspondingly as the absolute value of the station latitude decreases, which is consistent with the data observed earlier.

From the table, we can also note that the number of contacts also decreases with decreasing station latitude. This indicates that greater coverage of stations at latitudes

close to the inclination angle are just due to higher frequency of contacts, and not due to longer individual links achieved.

We continue our analysis to determine the amount of throughput that can be achieved from the ground station by examining the total coverage of each ground station. In particular, it is of practical value to determine how many ground stations, and which ones, satisfy the coverage and throughput requirements for a certain application. To achieve a particular throughput requirement, it would be wise to select the ground stations that provide the best coverage, so as to reduce the number of ground stations needed. To do this, we sort the ground stations in order of decreasing total coverage as shown in Table 3.4, and calculate the cumulative total coverage.

|                    |           |           | Cumulative Total Coverage |          | Data Throughput (Gb) at various transmit rates (Gbps) |         |          |
|--------------------|-----------|-----------|---------------------------|----------|---|---------|----------|
|                    | Total     | Lat (deg) | 10 days                   | 1 day    | 0.180   | 0.360   | 0.620    |
| Madrid             | 17,969.94 | 40.43     | 17,969.94                 | 1,797.0  | 323.5   | 646.9   | 1,114.1  |
| S Pac Fr Keuguelen | 17,651.89 | -49.35    | 35,621.83                 | 3,562.2  | 641.2   | 1,282.4 | 2,208.6  |
| Colorado Springs   | 14,849.46 | 38.81     | 50,471.29                 | 5,047.1  | 908.5   | 1,817.0 | 3,129.2  |
| Wallops            | 14,447.23 | 37.95     | 64,918.52                 | 6,491.9  | 1,168.5   | 2,337.1 | 4,024.9  |
| Tokyo              | 12,780.92 | 35.71     | 77,699.44                 | 7,769.9  | 1,398.6   | 2,797.2 | 4,817.4  |
| Canberra           | 12,445.32 | -35.41    | 90,144.76                 | 9,014.5  | 1,622.6   | 3,245.2 | 5,589.0  |
| Vandenberg         | 11,979.55 | 34.58     | 102,124.31                | 10,212.4 | 1,838.2   | 3,676.5 | 6,331.7  |
| Perth              | 11,221.19 | -31.80    | 113,345.50                | 11,334.6 | 2,040.2   | 4,080.4 | 7,027.4  |
| Santiago           | 10,734.49 | -33.15    | 124,080.00                | 12,408.0 | 2,233.4   | 4,466.9 | 7,693.0  |
| Hartebeeshoek      | 9,483.24  | -25.89    | 133,563.23                | 13,356.3 | 2,404.1   | 4,808.3 | 8,280.9  |
| Hawaii             | 9,036.74  | 21.32     | 142,599.98                | 14,260.0 | 2,566.8   | 5,133.6 | 8,841.2  |
| Guam               | 8,826.74  | 13.62     | 151,426.72                | 15,142.7 | 2,725.7   | 5,451.4 | 9,388.5  |
| Bangalore          | 8,239.37  | 13.03     | 159,666.08                | 15,966.6 | 2,874.0   | 5,748.0 | 9,899.3  |
| Am Samoa           | 8,102.67  | -14.33    | 167,768.75                | 16,776.9 | 3,019.8   | 6,039.7 | 10,401.7 |
| Ascension Island   | 7,943.29  | -7.92     | 175,712.04                | 17,571.2 | 3,162.8   | 6,325.6 | 10,894.1 |
| Arequipa           | 7,910.21  | -16.47    | 183,622.25                | 18,362.2 | 3,305.2   | 6,610.4 | 11,384.6 |
| Liberville         | 7,909.06  | 0.36      | 191,531.31                | 19,153.1 | 3,447.6   | 6,895.1 | 11,874.9 |
| Cocos Island       | 7,392.06  | -12.20    | 198,923.38                | 19,892.3 | 3,580.6   | 7,161.2 | 12,333.2 |
| Seychelles         | 7,326.34  | -4.67     | 206,249.72                | 20,625.0 | 3,712.5   | 7,425.0 | 12,787.5 |
| Kourou             | 7,175.17  | 5.21      | 213,424.89                | 21,342.5 | 3,841.6   | 7,683.3 | 13,232.3 |

**Table 3.4. Cumulative Coverage and throughput for stations.**

Of course, there are some overlap between the stations, so the cumulative totals will be greater than the actual scenario, where the satellite would communicate with only

one of the ground stations that it has contact with at a time. Regardless, this provides an initial determination of the approximate number of ground stations needed before further analysis.

Based on the cumulative total coverage available, a daily throughput is calculated for three transmit speeds: 180 Mbps, 360 Mbps, and 622 Mbps. From this data, we can determine that for example, an application that requires 1,500 Gb throughput per day can either use the first 6 stations transmitting at 180 Mbps, or the first 3 stations transmitting at 360 Mbps, or just the first 2 stations transmitting at 622 Mbps.

This methodology will be used in the next chapter in order to determine the ground stations needed for an image download application, and the coverage characteristics associated with these selected ground stations.

## Chapter 4: Analysis of Imaging Application

Using the methodology developed earlier, we next turn our attention to analyzing the communications performance of one example of a typical scientific data scenario that may need to be supported from the ISS. We focus on an imaging application on the ISS, working in a store-and-forward mode, that will take images of the surface of the earth or, depending on the type of on-board instruments available, collect other data on or under the earth surface into an image format. The images are temporarily stored onboard the ISS, and downloaded to the ground at the next available ISS contact with a ground station.[11]

We are focusing on a commercial application with the minimum requirement of being able to download at least 120 images per day, with each image being compressed to about 12 Gbits. These images, which require a total throughput of 1,440 Terabits in every 24-hour period, must be available for commercial customers in the US. We will determine in this section the ground stations needed to provide this throughput requirement.

### 3.6 Assumptions

For this application, we will assume a nominal ISS antenna cone angle of 60 degrees, and a minimum elevation angle of 10 degrees for all ground stations. From the analysis discussed earlier, we already know that we would achieve greater coverage for stations near 40 degrees latitude, so we select NASA ground stations from the STK





cheaper communication links between the stations and to the Internet backbone without the need for inter-continental lines. Although our throughput requirement is 1.44 Terabits per day, it may appear that the first 5 US stations generating 1.495 Terabits is sufficient. However, the cumulative throughput here double counts incidents when there is contact with 2 stations at a time. Even if this is not the case, the small margin may not satisfy the requirements considering errors. We will thus continue our analysis with the first 6 US stations, which provide a daily throughput of 1.7 Terabits, equivalent to downloading 143 images.

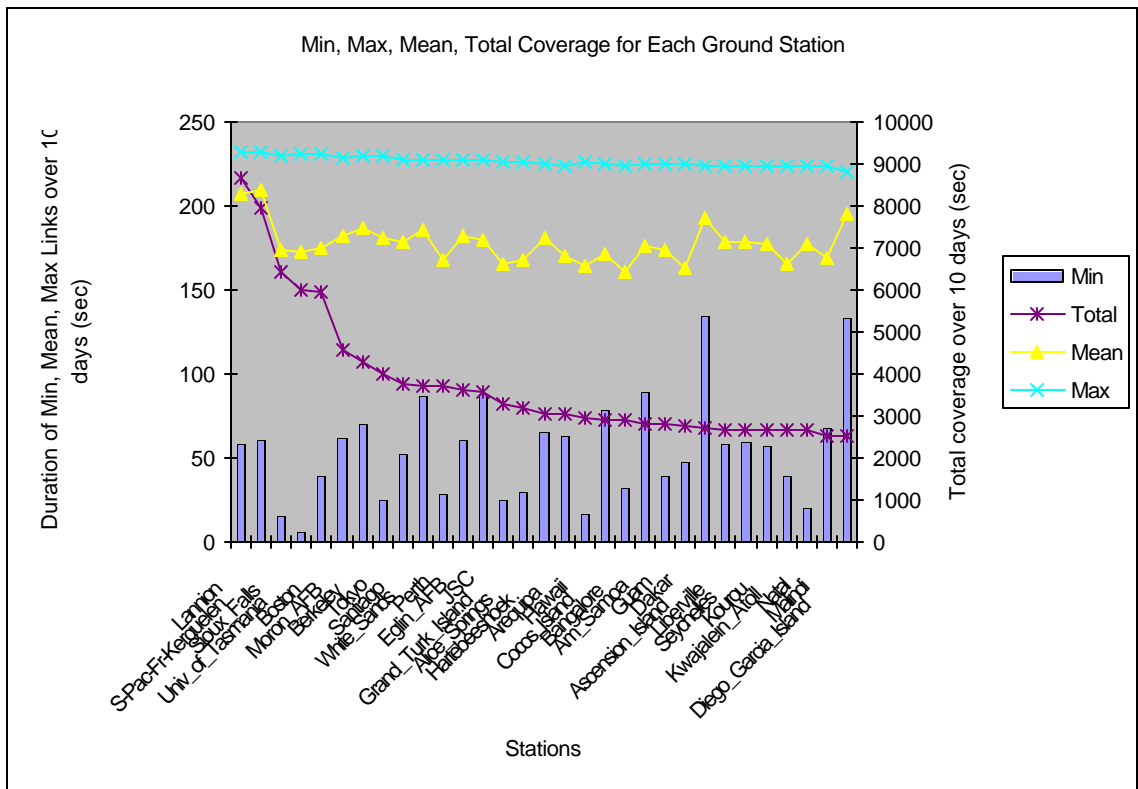

**Figure 4.2. Min, max, mean, total coverage for selected stations.**

The US ground stations are then grouped as a constellation in Satellite Tool Kit, and a chain is created that links the ISS antenna to the constellation of ground facilities. This arrangement allows us to calculate the coverage available from the ISS antenna to only one of the ground stations at a time to eliminate overlapping. Table 4.2 shows the coverage result from those 6 stations together, which can receive nearly 1.6 Terabits of data daily at a transmit rate of 622 Mbps. This is enough to download 12 spare images each day on top of the requirement of 120 images. This extra bandwidth could, instead, be leased to other customers that could use the communications link.

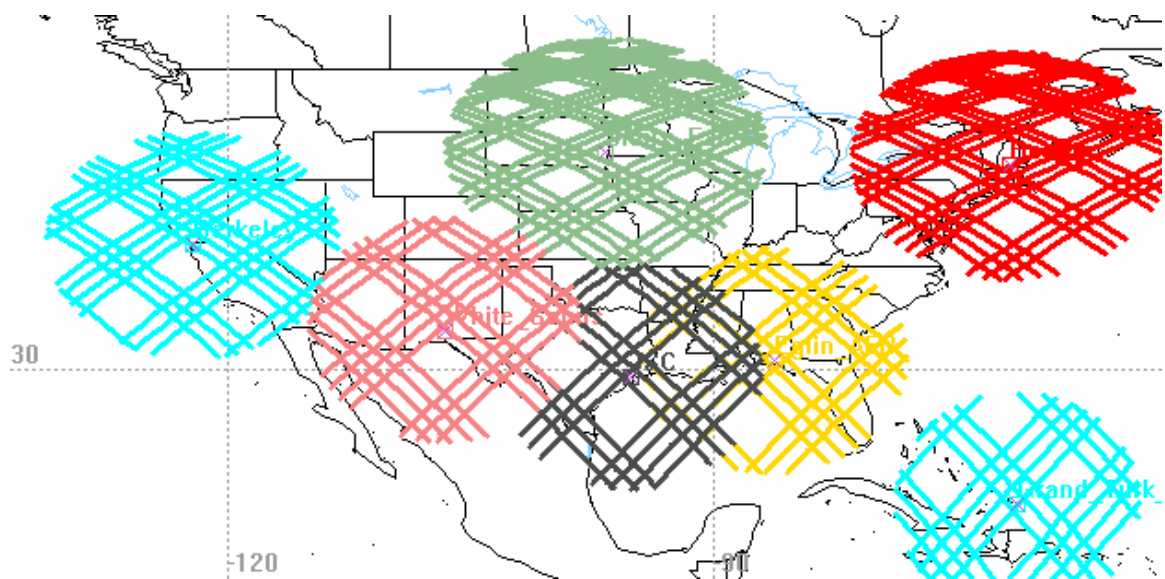

**Figure 4.3.** Ground track of 6 US ground stations showing ISS access.

|                     |              | Cumulative Total Coverage | Data Throughput (Gb) for specified transmit rates (Gbps) |          |         | # Image D/Ls for Image size (Gb): |         |       |       |       |
|---------------------|--------------|---------------------------|--|----------|---------|-----------------------------------|---------|-------|-------|-------|
|                     |              |                           | 10 days  | 1 day    | 0.180   | 0.361                             | 0.622   | 0.180 | 0.361 | 0.622 |
| <b>US</b>           | <b>Total</b> |                           |  |          | 0.180   | 0.361                             | 0.622   | 0.180 | 0.361 | 0.622 |
| Sioux_Falls         | US           | 6415.523                  | 6,415.52   | 641.6    | 115.5   | 231.6                             | 399.0   | 9     | 19    | 33    |
| Boston              | US           | 5967.755                  | 12,383.28  | 1,238.3  | 222.9   | 447.0                             | 770.2   | 18    | 37    | 64    |
| Berkeley            | US           | 4301.791                  | 16,685.07  | 1,668.5  | 300.3   | 602.3                             | 1,037.8 | 25    | 50    | 86    |
| White_Sands         | US           | 3723.055                  | 20,408.12  | 2,040.8  | 367.3   | 736.7                             | 1,269.4 | 30    | 61    | 105   |
| Eglin_AFB           | US           | 3633.435                  | 24,041.56  | 2,404.2  | 432.7   | 867.9                             | 1,495.4 | 36    | 72    | 124   |
| JSC                 | US           | 3585.289                  | 27,626.85  | 2,762.7  | 497.3   | 997.3                             | 1,718.4 | 41    | 83    | 143   |
| Lannion             |              | 8684.035                  | 36,310.88  | 3,631.1  | 653.6   | 1,310.8                           | 2,258.5 | 54    | 109   | 188   |
| S-Pac-Fr-Kerguelen  |              | 7975.844                  | 44,286.73  | 4,428.7  | 797.2   | 1,598.8                           | 2,754.6 | 66    | 133   | 229   |
| Univ_of_Tasmania    |              | 6023.566                  | 50,310.29  | 5,031.0  | 905.6   | 1,816.2                           | 3,129.3 | 75    | 151   | 260   |
| Moron_AFB           |              | 4556.708                  | 54,867.00  | 5,486.7  | 987.6   | 1,980.7                           | 3,412.7 | 82    | 165   | 284   |
| Tokyo               |              | 3983.483                  | 58,850.48  | 5,885.0  | 1,059.3 | 2,124.5                           | 3,660.5 | 88    | 177   | 305   |
| Santiago            |              | 3747.559                  | 62,598.04  | 6,259.8  | 1,126.8 | 2,259.8                           | 3,893.6 | 93    | 188   | 324   |
| Perth               |              | 3695.231                  | 66,293.27  | 6,629.3  | 1,193.3 | 2,393.2                           | 4,123.4 | 99    | 199   | 343   |
| Grand_Turk_Island   |              | 3302.632                  | 69,595.91  | 6,959.6  | 1,252.7 | 2,512.4                           | 4,328.9 | 104   | 209   | 360   |
| Alice_Springs       |              | 3180.739                  | 72,776.65  | 7,277.7  | 1,310.0 | 2,627.2                           | 4,526.7 | 109   | 218   | 377   |
| Hartebeeshoek       |              | 3071.249                  | 75,847.89  | 7,584.8  | 1,365.3 | 2,738.1                           | 4,717.7 | 113   | 228   | 393   |
| Arequipa            |              | 3069.96                   | 78,917.85  | 7,891.8  | 1,420.5 | 2,848.9                           | 4,908.7 | 118   | 237   | 409   |
| Hawaii              |              | 2963.495                  | 81,881.35  | 8,188.1  | 1,473.9 | 2,955.9                           | 5,093.0 | 122   | 246   | 424   |
| Cocos_Island        |              | 2909.732                  | 84,791.08  | 8,479.1  | 1,526.2 | 3,061.0                           | 5,274.0 | 127   | 255   | 439   |
| Bangalore           |              | 2899.187                  | 87,690.27  | 8,769.0  | 1,578.4 | 3,165.6                           | 5,454.3 | 131   | 263   | 454   |
| Am_Samoa            |              | 2811.635                  | 90,501.90  | 9,050.2  | 1,629.0 | 3,267.1                           | 5,629.2 | 135   | 272   | 469   |
| Guam                |              | 2788.092                  | 93,290.00  | 9,329.0  | 1,679.2 | 3,367.8                           | 5,802.6 | 139   | 280   | 483   |
| Dakar               |              | 2770.107                  | 96,060.10  | 9,606.0  | 1,729.1 | 3,467.8                           | 5,974.9 | 144   | 288   | 497   |
| Ascension_Island    |              | 2692.313                  | 98,752.42  | 9,875.2  | 1,777.5 | 3,565.0                           | 6,142.4 | 148   | 297   | 511   |
| Liberville          |              | 2682.726                  | 101,435.14   | 10,143.5 | 1,825.8 | 3,661.8                           | 6,309.3 | 152   | 305   | 525   |
| Seychelles          |              | 2670.296                  | 104,105.44   | 10,410.5 | 1,873.9 | 3,758.2                           | 6,475.4 | 156   | 313   | 539   |
| Kourou              |              | 2668.276                  | 106,773.71   | 10,677.4 | 1,921.9 | 3,854.5                           | 6,641.3 | 160   | 321   | 553   |
| Kwajalein_Atoll     |              | 2657.01                   | 109,430.72   | 10,943.1 | 1,969.8 | 3,950.4                           | 6,806.6 | 164   | 329   | 567   |
| Natal               |              | 2655.1                    | 112,085.82   | 11,208.6 | 2,017.5 | 4,046.3                           | 6,971.7 | 168   | 337   | 580   |
| Malindi             |              | 2539.013                  | 114,624.84   | 11,462.5 | 2,063.2 | 4,138.0                           | 7,129.7 | 171   | 344   | 594   |
| Diego_Garcia_Island |              | 2534.842                  | 117,159.68   | 11,716.0 | 2,108.9 | 4,229.5                           | 7,287.3 | 175   | 352   | 607   |

**Table 4.1. Cumulative access data and throughput for 31 stations.**

|               |             | Data Throughput (Gbps) |       |         | # Images | Gb / image: |       |
|---------------|-------------|------------------------|-------|---------|----------|-------------|-------|
| Total 10 days | Total 1 day | 0.180                  | 0.361 | 0.622   | 0.180    | 0.361       | 0.622 |
| 25629.645     | 2562.9645   | 461.3                  | 925.2 | 1,594.2 | 38.4     | 77.1        | 132.8 |

**Table 4.2. Complete chain access and throughput for 6 US ground stations.**

In the following sections, we will discuss the financial aspects of this application, and compare it to the cost of other ISS communications architectures.

## Chapter 5: Cost Analysis & Comparison

Our focus is not on just communication performance optimization but on a system-level comparison of alternatives. In order to determine a cost comparison between the direct-to-ground option and other communications architectures, we look in this section at the cost components that vary among these communication alternatives. The costs considered in these calculations are only the communication costs that vary among the three different architectures. Not considered in these cost estimates are the data processing center for the instrument, the payload operations center, the instrument itself, or other SG&A operating costs since these are assumed to be the same for all architectures.

As this is an approximate comparison and not a full financial analysis of these systems, which would require much additional information that may be proprietary, these estimates assume no inflation, no interest, and costs are all in the current year's value.

Because there are currently already over 320 ground stations at over 66 NASA facilities distributed at strategic locations throughout the globe, there is little need to build additional facilities for communications purposes. Although there are areas of the world where there would be great benefit for having a ground facility, these are either remote areas or in countries with whom the US has not had a long history of favorable relations. Thus, for this analysis, we will only consider installing additional Ka-band terminals on existing NASA ground facilities. This saves the cost of having to build new facilities, and only incurs the incremental cost of adding additional terminals and staff to operate and maintain the terminals.

Summary of Overall Assumptions:

- No inflation
- No interest
- All costs in current year
- Only current NASA facilities are used
- Only incremental costs to install additional terminals & staff are considered
- Only communications costs that are different among the 3 architectures are considered
- Costs will be estimated for up to 5 years of operation
- The ground segment costs apply to RDT&E Only (the Ground Segment can be used for multiple satellites at no incremental cost)

## **5.1 Cost Breakdown Structure**

This cost estimate will focus on the cost for establishing a communication system on the ISS, terminals on the ground to receive the data, ground infrastructure to distribute the data, and personnel to develop and maintain the system.

The system will include the segments below, and Figure 5.1 shows a graphical Cost Breakdown Structure (CBS) of the system.

1. Space Segment:
  - Research and development of antenna and communications electronics
  - Production of antenna and communications electronics
2. Ground Segment:
  - Communications equipment & facilities

- Systems level setup
3. Launch Segment:
- Launch of antenna and communications electronics
  - Insurance
4. Operations & Maintenance

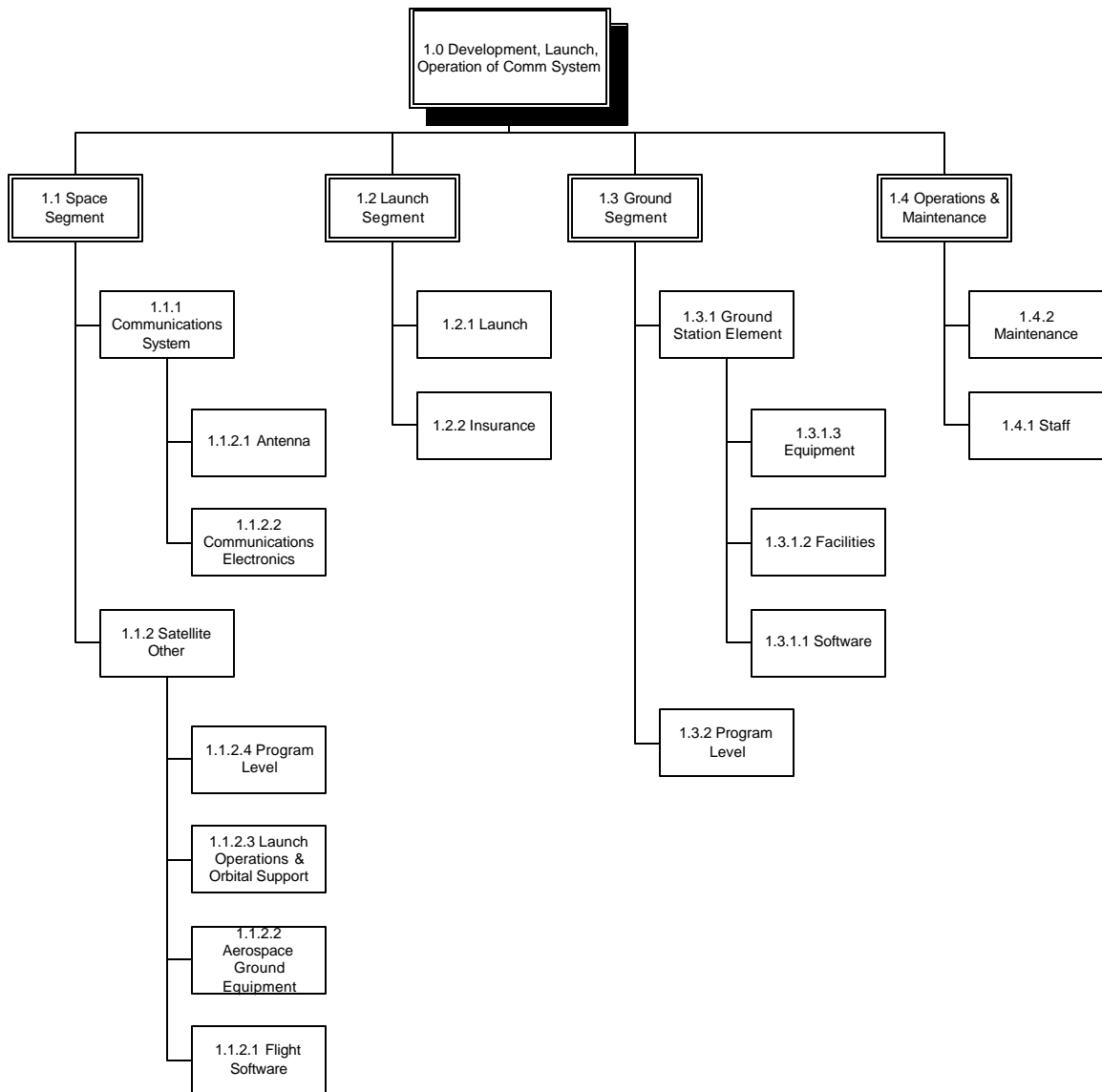

**Figure 5.1. Work breakdown structure for direct to ground communication system.**

### **5.1.1 Space Segment**

This segment comprises the research, development, testing, and evaluation (RDT&E) of the downlink antenna onboard the ISS and its corresponding communications electronics. The cost for RDT&E will be calculated separately from the cost of production of the system.

### **5.1.2 Launch Segment**

Once research, development, and production of the ISS communication system is complete, it must be launched and installed on the ISS. The launch cost for aerospace systems are generally not insignificant compared to the rest of the costs.

The launch segment does not have as much breakdown as other components of the system, primarily because it is contracted out to a company that manufactures launch vehicles and launches the satellite for the satellite communications company. However, because this segment places significant costs to the overall system, it deserves its own category at the second level. Components of this segment simply include:

#### **Launch of the System:**

The cost for the launch vehicle (shuttle in this case) used to launch the system into orbit, and the support provided during launch.

**Insurance:** Insurance in the event that the launch is unsuccessful, and either leaves the system stranded in a useless orbit, or destruction of the satellite and/or launch vehicle. This includes insurance for the actual launch of the satellite, and the satellite itself.



### 5.1.3 Ground Segment

This segment includes all the hardware, facilities, and management needed to establish the ground infrastructure to support the satellites. This element consists of components that make up the ground stations to communicate with the satellite. As shown in Figure 6, this includes:

**Software:** Software for the computers on the ground.

**Facilities:** Buildings and offices.

**Equipment:** Antennas, receivers, transmitters, RF electronics, computers, and other equipment.

### 5.1.4 Operations and Maintenance

Although this segment is not a very large contributor of costs to the overall system, it is an important aspect in the lifetime of the system, as it includes the annual operations and maintenance of the system over time. This includes the staff required to work on shifts to monitor and control the terminals and instruments, and the maintenance of the equipment in the ground facilities.

## 5.2 Costing Methods

Because this is a large-scale system with very complex components, conventional cost estimating methods such as detailed estimating may not be applicable or practical. Instead, much of the estimates in this system will be based on parametric analysis of

components of the system. Research on costs of similar satellite systems by the commercial sector and US Department of Defense have resulted in the development of individual Cost Estimating Relationships (CER's) [12] that express the cost of a component as a function of design sizing, performance variables or other parameters.

The Cost Estimating Relationship equations have the following general form:

$$Cost = c + a \times x^b$$

where

*Cost* is the cost of the component

*c* is a constant

*a* is a coefficient

*x* is the parameter that is a property of the component (e.g. weight, size, etc.)

*b* is an exponential

The values of *c*, *a*, and *b* are obtained from sources[12] that have used empirical data to formulate these equations. Where appropriate, complexity factors are applied to parameters to account for technology changes. A factor of 1 represents current technology, while factors greater than 1 represent advanced technologies that incur more research and development costs. Components with a factor less than 1 have technology that has been fully researched, well known, and relatively simple. A separate CER is used for the RDT&E (Research, Development, Testing & Evaluation) phase and for the production of the TFU (Theoretical First Unit). For multiple units, a learning curve factor can be applied to the cost of the TFU.

$$\text{Total production cost for } N \text{ units} = TFU \times L$$

where

$$L = N^B$$

$$B = 1 - \frac{\ln(100\% / S)}{\ln 2}$$

where  $S$  is the percentage reduction in cumulative average cost when the number of production units is doubled. Because much of this cost estimate is based on parametric equations, which in turn is based on empirical data that has been fitted into equations, there will be errors associated with the accuracy of the equations. For each CER equation, there is a standard error for it listed in the calculations along with the CER in the cost estimate.

For other portions of the system where there are less complexity, such as the launch, other conventional methods of estimating are used. Direct Estimation means obtaining information about the cost of the component or service directly, either from the source itself, through general knowledge or experience in the field, or through a source that knows the information. Estimation by analogy means using another comparable system and obtaining similar costs with that system. Below is a summary of the costing methods used in this analysis.

| <u>Component</u>            | <u>Costing Method</u> |
|-----------------------------|-----------------------|
| <b>Space Segment</b>        |                       |
| Development of comm. system | Parametric Estimation |
| Production of comm. system  | Parametric Estimation |
| <b>Launch Segment</b>       |                       |
| Launch of satellites        | Direct Estimation     |
| Insurance                   | Parametric Estimation |
| <b>Ground Segment</b>       |                       |
| Ground Station Element      | Analogy Estimation    |
| Systems level               | Analogy Estimation    |

## **Operations & Maintenance**

Staff

Communications

Maintenance

Analogy Estimation

Direct Estimation

Parametric Estimation

### **5.3 Ground Segment**

The cost for the ground segment of a satellite communication system can be generally broken down into elements with the percentage breakdowns indicated in Table 5.1. The percentage breakdown was based on data from other satellite ground systems [12] and modified slightly to take into account relatively lower software costs today due to increased usage of commercial over-the-shelf (COTS) software. The cost for the equipment of each ground station includes the antenna and transmit / receive equipment for the station, which is all estimated to be about \$200,000. The remaining ground segment costs are calculated as relative percentages of the equipment cost.

Because there are only a few ground terminals and the cost of these terminals do not greatly impact the overall cost, we will ignore a learning curve. If there were great numbers of terminals being built, then there could be noticeable cost savings from building large numbers of stations and a learning curve could be applied. Based on the calculations, it will cost approximately \$606,000 for each ground station.

|                                 | % of Total<br>Ground Costs | Dev Cost as<br>% of SW<br>Cost | Cost per<br>station | Num<br>Stations | Total<br>Cost   |
|---------------------------------|----------------------------|--------------------------------|---------------------|-----------------|-----------------|
| <b>Ground Station Element</b>   |                            |                                |                     |                 |                 |
| Software (SW)                   | 27%                        | 82%                            | \$ 164              | 6               | \$ 982          |
| Facilities (FAC)                | 6%                         | 18%                            | \$ 36               | 6               | \$ 218          |
| Equipment (EQ)                  | 33%                        | 100%                           | \$ 200              | 6               | \$ 1,200        |
| Ground Station Element Subtotal |                            |                                | \$ 400              |                 | \$ 2,400        |
| <b>Systems Level</b>            |                            |                                |                     |                 |                 |
| Management                      | 6%                         | 18%                            | \$ 36               | 6               | \$ 218          |
| Systems Engineering             | 10%                        | 30%                            | \$ 61               | 6               | \$ 364          |
| Product Assurance               | 5%                         | 15%                            | \$ 30               | 6               | \$ 182          |
| Integration & Test              | 8%                         | 24%                            | \$ 48               | 6               | \$ 291          |
| Logistics                       | 5%                         | 15%                            | \$ 30               | 6               | \$ 182          |
| Systems Level Subtotal          |                            |                                | \$ 206              |                 | \$ 1,236        |
| <b>Total Ground Segment</b>     | 100%                       |                                | \$ 606              |                 | <b>\$ 3,636</b> |

*Table 5.1. Summary of Ground Segment costs.*

## 5.4 Operations & Maintenance

Running each ground station will include staff to operate and manage the station, regular maintenance, and communications lines to the Internet backbone. Because these terminals will be built on existing NASA facilities, only the incremental cost of additional staff and maintenance is incurred. We assume that one additional staff is needed at each ground station to operate and maintain the antenna and systems. The maintenance cost will be taken as a percentage (10%) of the ground station equipment, software, and facilities. In addition, communications links such as a T1 line for data and PSTN for voice will be needed, and is based on surveys of prices for such services. Communications costs for facilities located outside the US may incur additional inter-continental data lines. These figures in Table 5.2 show that it costs approximately \$230,000 to operate and maintain each ground station each year.

**Ground Operations**

|                      | Quantity per Station | Annual staff cost | Annual Cost |
|----------------------|----------------------|-------------------|-------------|
| Contractor Personnel | 1                    | \$ 140            | \$ 140      |
| Government Personnel | 0                    | \$ 95             | \$ -        |
| Subtotal Staff       |                      |                   | \$ 140      |

**Maintenance**

|             | Coeff | Ground Station Element Costs |            |        | Annual Cost |
|-------------|-------|------------------------------|------------|--------|-------------|
|             |       | SW                           | Facilities | Equip  |             |
| Maintenance | 10%   | \$ 164                       | \$ 36      | \$ 200 | \$ 40       |

**Communications**

|                      | Cost / year |
|----------------------|-------------|
| T1 Line, phone, etc. | \$ 50       |

**Summary**

|                         |               | Num Stations |                 |
|-------------------------|---------------|--------------|-----------------|
| Ground Operations       | \$ 140        | 6            | \$ 840          |
| Maintenance             | \$ 40         | 6            | \$ 240          |
| Communications          | \$ 50         | 6            | \$ 300          |
| <b>Total Annual Ops</b> | <b>\$ 230</b> |              | <b>\$ 1,380</b> |

*Table 5.2. Summary of Operations and Maintenance costs.*

## 5.5 Space Segment

The cost for space hardware is generally calculated in the aerospace community by CER's that are based mainly on mass. We assume a mass for the antenna of about 50 kg, and a mass for the communications electronics of about 40 kg. An additional 1.2 factor is applied to the RDT&E cost to take into account new technology for Ka-band phased array antenna equipment and its additional costs as compared to other common equipment. Because this is a phased array antenna, it may have less weight than a conventional antenna which has gimbaling mechanisms to enable tracking. As shown in Table 5.3, the cost for research, development, testing, and evaluation of the ISS direct to ground antenna and corresponding communications electronics is approximately \$26.8 million.

| RDT&E          |                     |       |                  |                              |       |     |                  |                      |           |  |
|----------------|---------------------|-------|------------------|------------------------------|-------|-----|------------------|----------------------|-----------|--|
| Cost Component | Parameter, X (Unit) | Value | Applicable Range | CER: Const + Coeff * X ^ Exp |       |     | Cost             | RDT&E Cost w/ Factor | Std Error |  |
|                |                     |       |                  | Const                        | Coeff | Exp |                  |                      |           |  |
| Antenna        | Wt (kg)             | 50    | 1-87             | 0                            | 1015  | .59 | \$ 10,206        | 1.2 \$ 12,247        | 1,793     |  |
| Electronics    | Wt (kg)             | 40    | 14-144           | 0                            | 917   | .7  | \$ 12,129        | 1.2 \$ 14,554        | 6,466     |  |
| Payload        |                     |       |                  |                              |       |     | <b>\$ 22,335</b> | <b>\$ 26,802</b>     |           |  |

**Table 5.3. CERs and costs for RDT&E of ISS antenna & communications systems.**

The cost of actual production of the communication system is defined by another CER equation below as shown in Table 5.4. Production of the first unit of the antenna and communication system is \$9.5 million.

| Production Cost for N units |                     |       |                              |       |      |                 |                  |                 |           |
|-----------------------------|---------------------|-------|------------------------------|-------|------|-----------------|------------------|-----------------|-----------|
| Cost Component              | Parameter, X (Unit) | Value | CER: Const + Coeff * X ^ Exp |       |      | N = ...         |                  |                 | Std Error |
|                             |                     |       | Const                        | Coeff | Exp  | 1               | 2                | 2nd Unit        |           |
| Antenna                     | Wt (kg)             | 50    | 20                           | 230   | 0.59 | First Unit      | 2 Units          | 2nd Unit        | 476       |
| Electronics                 | Wt (kg)             | 40    | 0                            | 179   | 1    | \$ 2,333        | \$ 4,432         | \$ 2,099        | 8,325     |
| Payload                     |                     |       |                              |       |      | \$ 7,160        | \$ 13,604        | \$ 6,444        |           |
|                             |                     |       |                              |       |      | <b>\$ 9,493</b> | <b>\$ 18,036</b> | <b>\$ 8,543</b> |           |

**Table 5.4. CERs and costs for production of ISS antenna & communications system.**

## 5.6 Launch Segment

The ISS downlink antenna and corresponding electronics will be launched by the Space Shuttle, which has a cost of bringing payloads into orbit of nearly \$10,000 per kg. In addition, a cost is added to account for insurance during the launch, and for the payload itself that are based on a percentage of the launch and payload cost respectively.

Table 5.5 shows that the total cost of the Launch segment is about \$2 million.

|                             |                     |                            |                       |
|-----------------------------|---------------------|----------------------------|-----------------------|
|                             | <b>Cost per Kg</b>  | <b>Payload weight (kg)</b> | <b>Launch Cost</b>    |
| Shuttle Launch              | \$ 9.1              | 90                         | \$ 819                |
|                             | <b>% of Launch</b>  | <b>Launch Cost</b>         | <b>Insurance Cost</b> |
| Launch Insurance            | 10%                 | \$ 819                     | \$ 82                 |
|                             | <b>% of Payload</b> | <b>Payload Cost</b>        | <b>Insurance Cost</b> |
| Payload Insurance           | 10%                 | \$ 9,493                   | \$ 949                |
| Insurance Subtotal          |                     |                            | \$ 1,031              |
| <b>Total Launch Segment</b> |                     |                            | <b>\$ 1,980</b>       |

**Table 5.5. Launch Segment costs summary.**

## 5.7 Summary of Costs

As shown in Table 5.6, it costs about \$51 million for the initial research, development, and production of the ground stations and ISS onboard antenna and communication systems. This cost, combined with the annual operating cost of \$1.38 million, yields the cost for up to the first year of operation of \$52.8 million. Thereafter, there is the \$1.38 million operating cost per year.



|                             |           |
|-----------------------------|-----------|
| <b>Space Segment Costs</b>  |           |
| ISS onboard antenna RDT&E   | \$ 26,802 |
| ISS onboard antenna Prod    | \$ 9,493  |
| Program Level               | \$ 9,649  |
| <b>Ground Segment Costs</b> |           |
| Ground Station Elements     | \$ 2,400  |
| System Level                | \$ 1,236  |
| <b>Launch Segment Costs</b> |           |
| Shuttle Launch              | \$ 819    |
| Insurance                   | \$ 1,031  |
| Total Initial Dev           | \$ 51,429 |

|                            |    |               |          |          |          |          |
|----------------------------|----|---------------|----------|----------|----------|----------|
| <b>Operations</b>          |    | <b>1</b>      | <b>2</b> | <b>3</b> | <b>4</b> | <b>5</b> |
| Ground Operations          | \$ | 840           | \$ 840   | \$ 840   | \$ 840   | \$ 840   |
| Maintenance                | \$ | 240           | \$ 240   | \$ 240   | \$ 240   | \$ 240   |
| Communications             | \$ | 300           | \$ 300   | \$ 300   | \$ 300   | \$ 300   |
| Operations Subtotal        | \$ | <b>1,380</b>  | \$ 1,380 | \$ 1,380 | \$ 1,380 | \$ 1,380 |
| <b>Total Comm Expenses</b> | \$ | <b>52,809</b> | \$ 1,380 | \$ 1,380 | \$ 1,380 | \$ 1,380 |

**Table 5.6. Total cost summary of ISS direct to ground communication system.**

Assuming amortization in 3 years and the daily throughput calculated earlier in Chapter 4, the direct-to-ground system is estimated to cost the owner about \$.25 per Megabyte during the first 3 years, as shown in Table 5.7. This is the cost to the owner of the system for researching and building his own system to downlink data from the ISS imaging instrument. If there is excess capacity, it could be leased to potential customers at a price higher than this, possibly at approximately \$.40 per Megabyte.

| Thru-put / day (Mb) | Thru-put / Yr (Tb) | Yrs to Amort | Total Thru-put (Tb) | Cost til Amort | Cost / Mbit | Cost / MByte |
|---------------------|--------------------|--------------|---------------------|----------------|-------------|--------------|
| 1,600,000           | 584                | 3            | 1,752               | \$ 55,569      | \$ 0.03     | \$ 0.25      |

**Table 5.7. Summary of cost per unit of data for ISS direct to ground system.**

## 5.8 Comparison with Commercial Constellation

It would be interesting to compare the characteristics of the direct to ground (DTG) system with other planned commercial satellite systems that can be used to relay data down to the ground. As discussed in Chapter 2, Table 2.2 shows a listing of some of these commercial systems planning to transmit data in Ka-band and other bands.

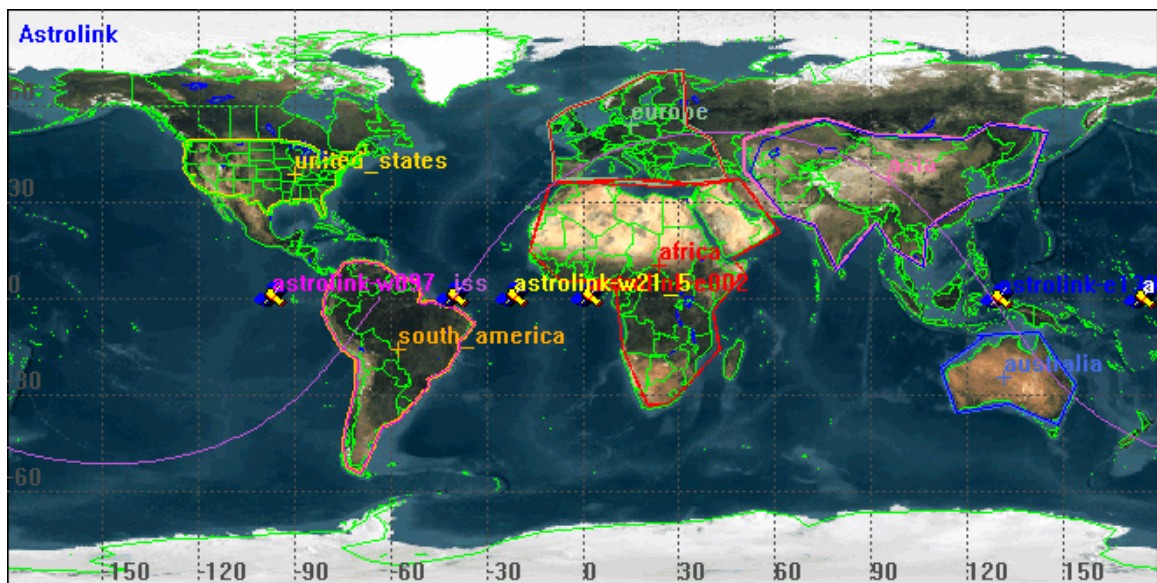

*Figure 5.2. Proposed Astrolink system.*

Astrolink is likely one of the better candidates to possibly start operations in the next few years. This system, shown in Figure 5.2, has a total throughput of 6.5 Gbits per second and (in its final form) would be comprised of 9 geostationary satellites in 5 orbital positions distributed mainly over largely populated areas of the globe. The satellites will be capable of download speeds of up to 20-110 Mbps through multiple spot beams of 0.8 degrees operating in the Ka-band at approximately 30 GHz uplink and 20 GHz downlink.

The system back-bone architecture is ATM based, and is estimated to cost about \$3.6 billion during the first phase.[8]

Because this is a commercial system that is not yet in service, accurate information on the coverage areas and the directions of the antenna beams are not publicly available. However, the target service areas are known, and from this information, we can assume the direction to which antennas onboard the satellites point. A scenario of the Astrolink system has been modeled in STK with “target areas” in the shape of the US, South America, Europe, Africa, Asia, and Australia representing the target service areas. These are shown in the previous Figure 5.2 with each of these continents / countries outlined in different colors. Because the outline of the actual spot beams on the real satellites will likely follow the contour of the service areas, the sensors onboard the satellites were modeled in the shape of those area targets. This is to simulate multiple spot beams pointing towards, for example, the United States that collectively would appear as one large beam following the contour of the US.

Figure 5.3 shows a representative model of the beams from the Astrolink satellites. In it, the Astrolink satellite positioned at  $-97$  degrees longitude has a set of two beams, one for the US and one for South America, pointed to those areas. The ISS is shown in its orbit (much closer to the surface of the earth than the Astrolink satellite) over South America with its orbit in yellow and a line connecting from the ISS to the Astrolink satellite showing access in its field of view.

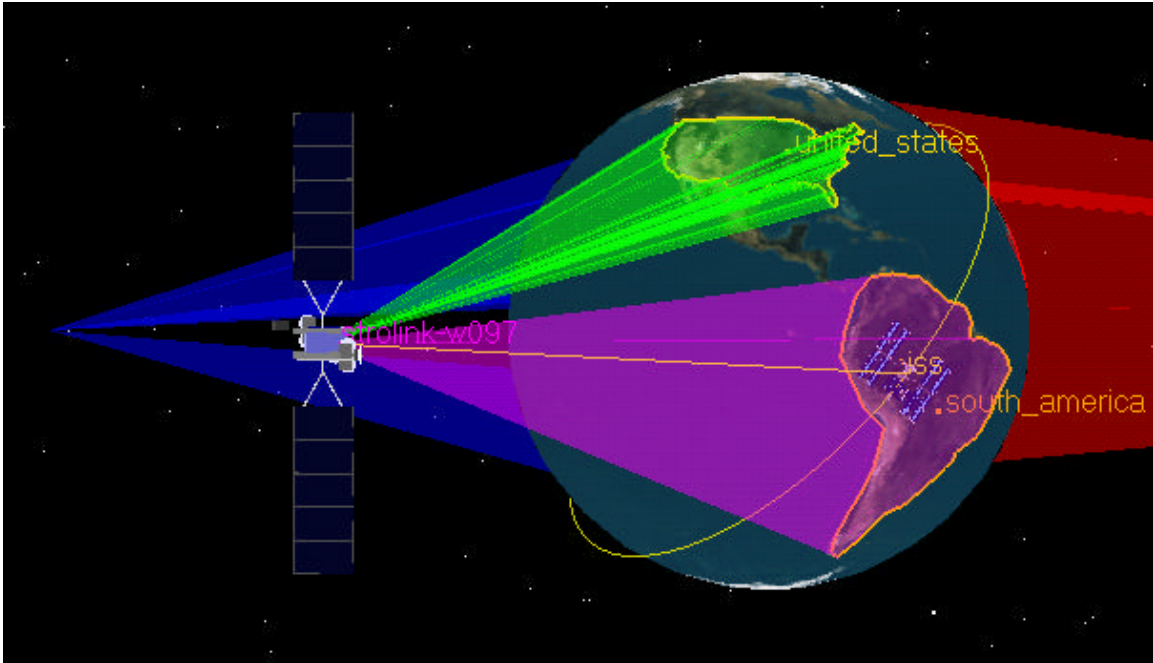

***Figure 5.3. Model of Astrolink satellite covering main continents with access to ISS.***

The Astrolink system is capable of providing service to these areas at a minimum elevation angle of 20 degrees. A coverage analysis of this setup of the Astrolink system with this minimum elevation angle shows that it can provide coverage for the ISS of up to 144,547 seconds over 10 days, or 16.7 percent of the time. This translates into a throughput of about 5.2 Terabits per day at a transmit rate of 361 Mbps. This level of coverage is likely to be satisfactory for most store and forward type applications such as downloading images. For real-time video applications, however, this would still not provide enough coverage.

The backers of the system plan to have a service charge that is usage based, at a rate of \$0.05 to \$0.5 per Megabyte of transmitted data. This figure issued by the company is likely to be on the low end, and the actual cost may be higher. The cost estimated for the

direct to ground architecture, however, falls into this range, at approximately \$0.25 per Megabyte.

## 5.9 Comparison with TDRSS

The TDRS system comprises of seven satellites that provide 100% of coverage by design. This would be the system of choice for real-time applications such as video conferencing or real-time access to science data onboard the ISS. The old TDRS system, however, does not support Ka-band. There is currently only one satellite, TDRS-8 (formerly TDRS-H) that provides Ka-band service. However, Figure 5.4 shows that using even only this satellite provides a very good amount coverage: 499,089 seconds over 10 days, or 57.7% of the time. This is equivalent to 15 Terabits of data per day transmitting at 300 Mbps.

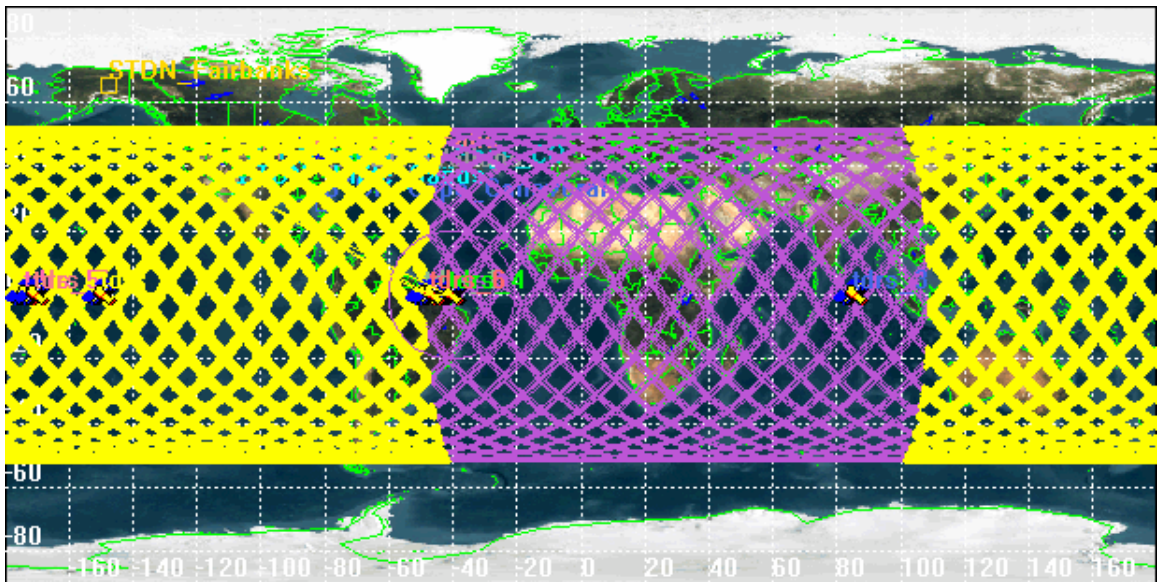

*Figure 5.4. ISS Ground track with coverage by just TDRS-8 (highlighted in yellow).*

If we can live with the current TDRS system, coverage is 100%, as shown in Figure 5.5, and the throughput is even higher. This complete coverage, however, is achieved only if the Guam ground station is also used due to a “Zone of Exclusion” over the Indian ocean where the White Sands Complex cannot see the TDRS satellites. Downloading to the Guam station could mean additional costs incurred to deliver the data through expensive inter-costal lines. Complete coverage is likely not needed for most applications, so a coverage analysis for using only the White Sands Complex (WSC) is also performed. The coverage provided by the TDRS satellites transmitting only to the WSC is shown in Figure 5.6, and is 819,172 seconds over 10 days, or an impressive 94.8% of the time, capable of throughputs of up to 25 Terabits per day transmitting at 300 Mbps. (As discussed before, the current Ku-band system is limited to speeds of up to 300 Mbps.)

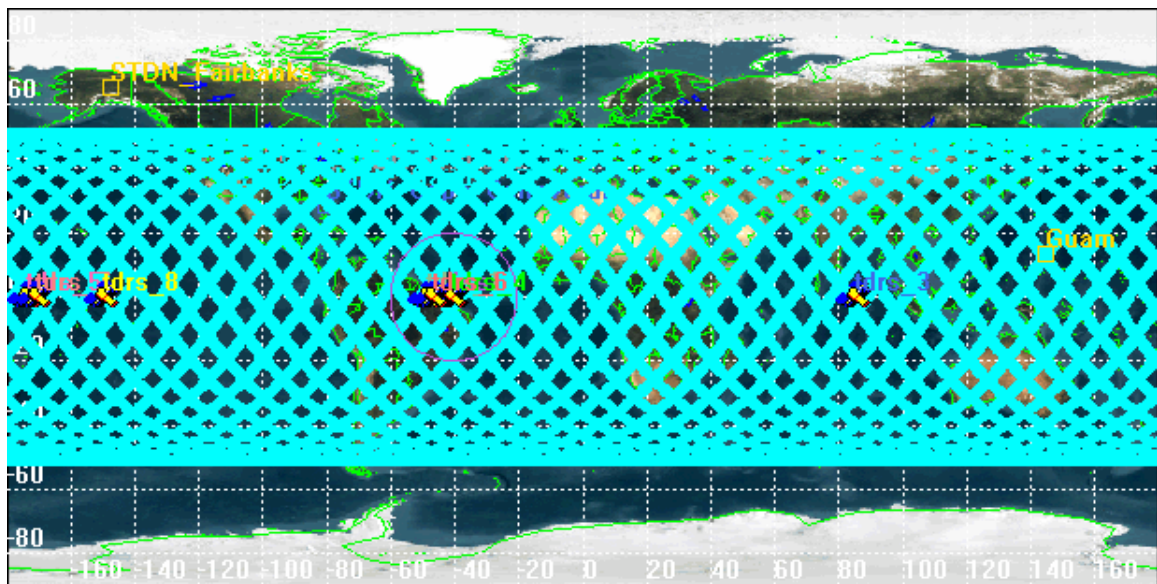

**Figure 5.5. ISS Ground track with coverage by entire TDRSS.**



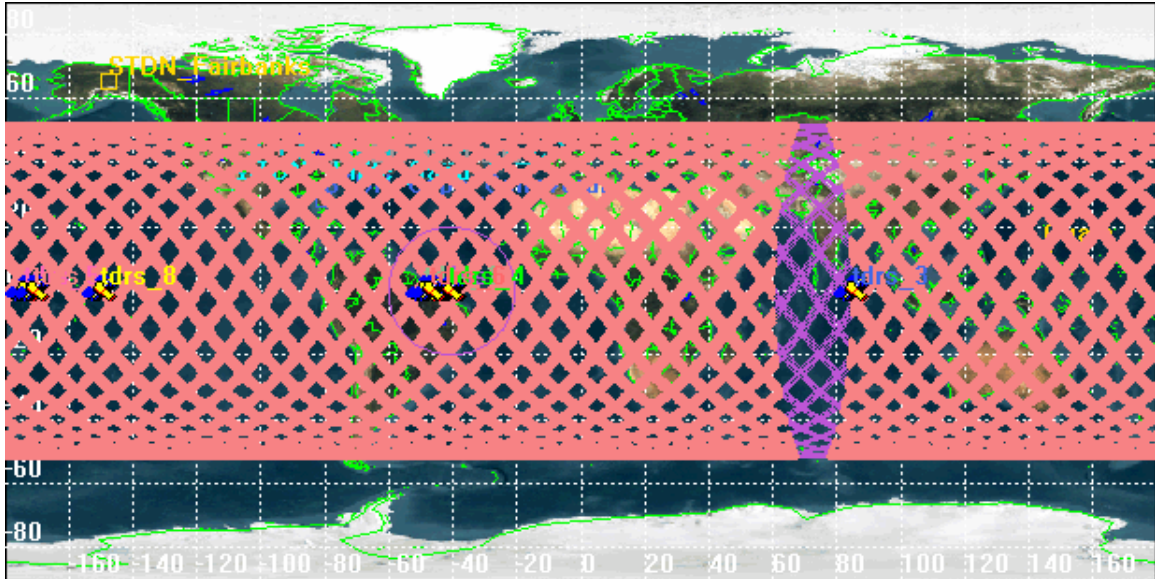

***Figure 5.6. ISS Ground track with coverage by just TDRSS with just White Sands Complex (highlighted in pink).***

As a comparison, the cost for relaying data through the current TDRSS system operating in the Ku-band ranges from \$200 to \$300 per minute, or \$0.09 to \$13 per Megabyte if transmitting at 300 Mbps.[13],[14] The cost for usage of the new Ka-band satellites is likely to be significantly higher during the next couple years before all of the new satellites are launched and enough usage has been gained to lower the price. Nevertheless, the cost for the DTG option appears to be competitive with using the TDRSS.

## Chapter 6: Summary and Future Work

### 6.1 Summary

We have discussed three communications architectures that represent possible options for future communications needs of the ISS: 1) using the existing NASA TDRSS, 2) using a commercial relay system, and 3) communicating directly from the ISS to the ground. We focused on an analysis of the coverage and performance characteristics of the direct to ground option and a simple cost estimate of this option. This was then compared to the other two alternatives.

Simulations of scenarios involving the ISS and ground stations distributed at various locations showed that the ground facilities' longitudinal position did not affect the satellite's coverage over a sufficiently long simulation period. The facilities' latitudinal position, however, had a direct impact on coverage. The plot of coverage with respect to station latitude shows two local maxima near the inclination of the satellite, and a local minimum at zero degrees latitude. Thus, the optimum placement of ground facilities is at latitudes just below the inclination of the satellite.

The analysis shows that the direct to ground architecture would be a feasible option for certain applications such as downloading of large images. For an ISS antenna with scan angle of 60 degrees and minimum station elevation angles of 10 degrees, six ground stations in the continental US can provide over 2,500 seconds of coverage per day. This is equivalent to a daily throughput of 1.6 Terabits at a transmit rate of 622 Mbps, enough to download 120 images the size of 12 Gbits each with extra capacity left over. Additional NASA ground stations could be used to augment the coverage needed



depending on the application. Using all 31 stations selected in this study would provide as much as 11,506 seconds per day of coverage, or 13.3% of the time. Table 6.1 shows the coverage of the direct to ground option with the other two options.

|                     | <b>Direct to Ground</b> | <b>Astrolink</b> | <b>TDRSS (Ku)</b> |
|---------------------|-------------------------|------------------|-------------------|
| Percentage Coverage | 13.3%                   | 16.7 %           | 100%              |
| Transmit rate       | 622 Mbps                | Up to 110 Mbps   | 300 Mbps          |

**Table 6.1. Percentage coverage provided by three architectures. [15],[16]**

As seen in Table 6.2, the cost for the direct to ground option is comparable to that of the other services. It falls in the middle of the range of service fees that the Astrolink system plans to provide. It is likely that the Astrolink rates are optimistic and that the actual rates will be higher, while the speed may not be comparable to that available with a custom-made direct to ground system. The cost for using TDRSS Ku-band is slightly cheaper, which may be expected as new Ka-band services are now available at likely higher prices.

|                   | <b>Direct to Ground</b> | <b>Astrolink</b> | <b>TDRSS (Ku)</b> |
|-------------------|-------------------------|------------------|-------------------|
| Cost per Megabyte | \$0.25                  | \$0.05-\$0.5     | \$0.09-\$0.13     |
| Transmit rate     | 622 Mbps                | Up to 110 Mbps   | 300 Mbps          |

**Table 6.2. Cost per Megabyte for three architectures. [15],[16]**

Thus, it appears that:

- The direct to ground architecture is a good option for applications that do not require real time data transmission due to its low coverage percentage.
- However, the system does offer greater flexibility and scalability, and is suitable for applications where there is little initial usage, but could increase.
- The commercial relay architecture is an intermediate option, and is likely to be the most costly per Megabyte when all complete.

- Because the systems are not initially intended for fast-moving LEO satellites, it may not be as reliable or flexible.
- The TDRSS system is the best one to use for applications that require continuous link with the ISS, such as real-time videoconferencing or on-demand access to scientific data from an onboard instrument.
- The TDRSS system was designed for such relaying purposes, provides 100% coverage, and pricing is likely to remain competitive with other methods.
- Because of heavy usage of the system by NASA customers, however, it is unclear how much TDRSS usage NASA will be willing to allocate to commercial applications on the ISS.

Table 6.3 summarizes the advantages and disadvantages of the three options.

|               | <b>Direct to Ground</b>   | <b>Astrolink</b>   | <b>TDRSS (Ku)</b>  |
|---------------|---|--|--|
| Advantages    | <ul style="list-style-type: none"> <li>• Flexible</li> <li>• Scalable</li> <li>• Prices competitive</li> <li>• Good for store-and-forward applications</li> </ul> | <ul style="list-style-type: none"> <li>• Very little system setup required</li> </ul>  | <ul style="list-style-type: none"> <li>• 100% coverage</li> <li>• Good for real-time or on demand applications</li> </ul>  |
| Disadvantages | <ul style="list-style-type: none"> <li>• Not good for real-time applications</li> <li>• Requires additional building of facilities</li> </ul>                     | <ul style="list-style-type: none"> <li>• Prices and entire system uncertain</li> <li>• Systems not tailored to needs of ISS customers</li> </ul> | <ul style="list-style-type: none"> <li>• Possible slow ISS onboard communications system</li> <li>• Capacity for commercial applications may be limited later</li> </ul> |

*Table 6.3. Advantages and disadvantages of three architectures.*

## 6.2 Future Work

Additional studies can be performed to continue this study for other classes of systems besides the ISS. This could include user spacecraft with various types of antennas, and various types of orbits (such as LEO, MEO). Similarly, the study could be extended to similar classes of commercial relay constellations. Initial studies have already been done by the Center for Satellite and Hybrid Communication Networks (CSHCN) on comparison of MEO commercial constellations such as Orblink with MEO systems such as Astrolink and Spaceway and various classes of user spacecraft orbits.[17],[18],[19],[20] Some of these studies are included in the Appendices.

In addition, the results of this study could be coupled with other ongoing studies, and the coverage results could be tied to RF and other communication protocol studies. Effects on changing antenna size and power, for example, would have an impact on the antenna cone angle used in these studies. Optimum antenna choices could be derived from a combination of these studies.

Finally, if there is additional information such as pricing and cost estimates of commercial systems, a more sophisticated system could be developed with dynamic pricing. While NASA uses a rather flat pricing structure for its use of TDRSS (generally priced in dollars per minute), commercial systems could be based on various market conditions. Prices could be dynamically driven by the time (of day, month, or year), level of demand, amount of competition, level of service requested and frequency of service, and many other factors. Monte Carlo simulations could be conducted to view the effects of these changing market conditions and observe how pricing may be competitive with TDRSS and other communications architectures.



## Appendix A

Hadjitheodosiou, M., Nguyen, A., "Using Commercial Communication Satellite Constellations for Supporting Traffic From NASA Missions", Proceedings from 18th AIAA Intern. Conference on Satellite Systems & Communications, Oakland, CA, April 2000.

## USING COMMERCIAL COMMUNICATION SATELLITE CONSTELLATIONS FOR SUPPORTING TRAFFIC FROM NASA MISSIONS

Michael Hadjitheodosiou and Alex T. Nguyen  
*Center for Satellite & Hybrid Communication Networks*  
*Institute for Systems Research, A.V. Williams Building*  
*University of Maryland, College Park, MD 20742, USA*  
 Tel:+301-405-7904 Fax: +301-314-8586

### ABSTRACT

NASA is interested in using commercial satellites to provide broadband communications support for the International Space Station and other space missions. We describe a large-scale simulation model that we plan to use for detailed performance studies of critical parameters such as QoS guarantees for specific services, traffic routing schemes, transport protocol support, dynamic bandwidth allocation methods, queuing disciplines, and handoff strategies. In this paper we focus on the unique challenges we face and how we plan to use simulations to investigate:

- the feasibility of using proposed commercial constellations to carry mission telemetry, command and control, and tele-science traffic between ground terminals and near-earth spacecraft.
- the end-to-end performance optimization of such systems.

### Chapter 1: INTRODUCTION

The deployment of the International Space Station (ISS) that started in November of 1998 has ushered a new era in space exploration. At the same time, advances in communications technology could allow investigators on Earth to enjoy a virtual presence on board the ISS[1]. In order to achieve this, there will be a need to provide high quality, broadband communications connectivity in order to enable cost effective global access to experimental data from the ISS and other space missions. NASA is also interested to gradually facilitate broadband Internet services throughout its missions, eventually leading to a scenario where every spacecraft and instrument in NASA's network can have an IP address and a connection to the Internet[2].

Gradual commercialization of space communications

operations could enable:

- Reduction in cost for NASA's and ESA's broadband communication needs;
- Better, faster and easier dissemination of space mission and experimental data if some of the available bandwidth and global coverage of future commercial constellations can be utilized;
- Deployment of next generation commercial satellite constellations (since space agencies might become major customers);
- Faster development in the satellite industry and also enable other commercial entities to take part in experiments and development programs in space, such as future space habitats and planetary missions.

For these reasons we started an effort to investigate the use of next generation commercial satellite constellations for supporting broadband communications for the International Space Station (ISS). As a first step, we have developed a simulation model for this scenario, consisting of: the ISS, models of several commercial satellite constellations, the existing NASA Deep Space Network and the ground network of candidate commercial constellations. We consider this to be a minimal architecture, because all aspects of the model have been considered, including propagation characteristics, coverage aspects, traffic generation, node movement tracking, hand-off, and connectivity. This research work addresses the following topics:

- Determination, of particular traffic scenarios and QoS service requirements for an initial analysis scenario.
- Identification of potential commercial systems as

candidate for investigation, starting from simple GEO (existing) Ku/Ka-band systems and moving to the next generation Ka or V band MEO / LEO systems.

- Where necessary, application of analytical tools for traffic modeling, handoff analysis, fast end-to-end performance evaluation to derive performance bounds.
- Development of a detailed simulation model that includes network architecture & topology of Hybrid Network, and in particular:
- ISS (treated as an extremely LEO satellite) & ground network.
- Candidate Commercial Systems (constellation orbit model, ground network topology, information on routing options through constellation, Inter Satellite Links (ISLs) if any).
- Detailed simulation studies to quantify the performance of candidate satellite systems for specific services, protocols & traffic scenarios and recommend potential design modifications to ensure tele-science QoS requirements are met.

The performance parameters addressed include:

**Coverage assessment:** The purpose of this is to determine the maximum service time that can be made available to the ISS by the satellite constellation. (Percent of time that data could be transmitted to the ISS via the commercial satellite system - this includes Static & Dynamic coverage and the effect of Inter Satellite Links).

**Throughput assessment:** Maximum daily throughput depends on the availability duration (coverage statistics) and the per-channel data rate (link quality). Simultaneous data transmission on multiple channels must also be addressed in a complete model. Again, this must be specified in the ISS requirements for sending different data to different locations, and also to multicast or broadcast data to a number of locations.

**QoS assessment:** QoS is evaluated in terms of availability duration and link quality. Both quantities can be evaluated using the simulation model. Link quality is best described in terms of EIRP and G/T values that are specified in the ISS design and must be provided by the commercial constellation. Available duration can be computed based on the

results of the coverage analysis.

**Antennas & Terminals:** Antenna & earth terminal characteristics with respect to required link quality are considered. It would be necessary to have an antenna design well suited for covering moving satellites (in the non-GEO case) and terrestrial traffic.

In this paper we describe a large-scale simulation model that we use and focus on the unique challenges we face and how we use simulation to investigate:

- the feasibility of using proposed commercial constellations to carry mission telemetry, command and control, and tele-science traffic between ground terminals and near-earth spacecraft.
- the end-to-end performance optimization of such systems.

## Chapter 2: COMMUNICATIONS SUPPORT FOR THE INTERNATIONAL SPACE STATION

### Chapter 3: Simulation Model

Our general model consists of the ISS (treated as a satellite in an extremely Low Orbit) with a network of three ground stations. We plan to incorporate along with that detailed models of several proposed constellations, and see how each one performs for specific traffic scenarios. To illustrate our modeling process we describe here two characteristic cases, focusing more on the more challenging MEO case:

- A system with three GEO satellites. This along with the ground network model makes up a basic network similar to NASA's current TDRSS-Deep Space Network (DSN).
- A system with 7 MEO satellites in a ring, based on the proposed Orblink MEO system [3].

**ISS Module:** The ISS is currently modeled as a simple traffic generator. After a random idle period, it creates a file whose size is uniformly distributed. The file is then divided into fixed-size packets that are created and transmitted deterministically. Destination addresses for each file are determined randomly from among the nine end-user terminal addresses. All packets within a file are sent to the same end terminal. No priority or service classes are implemented. The queue\_sat module performs simple FIFO queuing, with a packet service time that is chosen to ensure proper flow control. There are

infinite capacity transmit queues on ISS. Packets are transmitted only if the strength of the beacon signal received from any satellite is above a threshold value that is a simulation attribute.

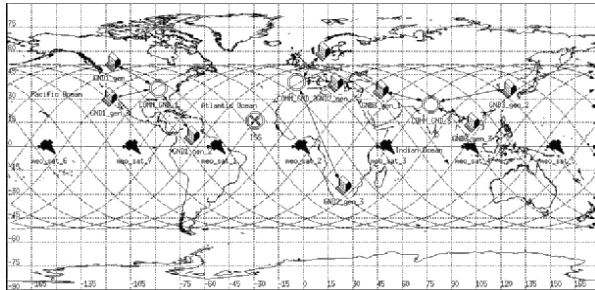

**Fig 1. OPNET network model-MEO Case**

**Chapter 4: Simulation Model Components-MEO Constellation**

Continuous monitoring of beacon signal strengths from available satellites ensures correct operation of Pointing, Acquisition and Tracking (PAT) subsystem on-board the ISS, as shown in the node model. The ISS\_beacon\_tx module continuously broadcasts beacon signals to allow other nodes in the network to locate the ISS. Beacon signals that are received from the satellites are processed by the ISS\_beacon\_rx module. The seven radio receivers measure the signal strength that of the beacon that is received from each satellite. The result is made available to the queue\_sat module to determine if the ISS can transmit packets.

The ISS-MEO handoff modules perform handover of the ISS transmit antenna. Based on the received signal strengths, the ISS\_antenna\_to\_sat is handed off between satellites. Handoff on-board the ISS is performed as hard handoff (break-before-make).

ISS\_once\_proc is responsible for initializing state variables, model attributes and process attributes, and maintains the integrity of the node model over multiple simulation runs.

Moving the MAC layer to ATM will allow us to support multiple services in addition to the present file transfer (video, long-duration connections, multicast, high-priority data, etc). Protocol support at ISS will ensure that QoS requirements are met for each service type. Complex input traffic models will be used to model the distribution of different service applications.

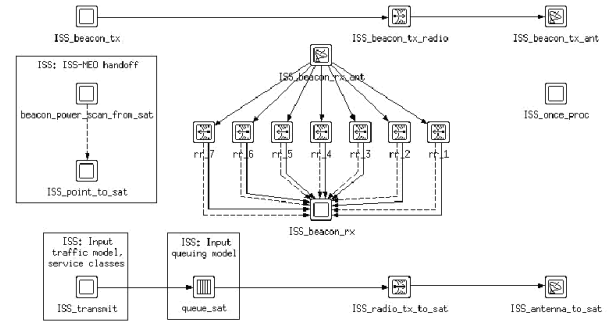

**Figure 2 ISS Module**

**MEO Satellite Module:** The MEO network is currently made up of 7 intelligent satellites, capable of OBP activity -- queuing, routing and handoff. Each satellite maintains continuous connections with its two adjacent satellites, and all 7 satellites form a ring in equatorial orbit at 9000 km. altitude. The meo\_point\_to\_meo module checks and maintains the connections between adjacent satellites. Each MEO satellite has multiple transmit-receive pairs to adjacent satellites, the ISS, and the three ground stations. These tx-rx pairs are identified by the transmitter and receiver modules that feed into the queuing modules (rx\_next\_sat, rx\_prev\_sat, etc.) and receive data from the routing and processing module.

When a satellite receives a packet, it identifies it as belonging to commercial or ISS traffic. Commercial traffic is fed into the meo\_pk\_queue while traffic to or from the ISS is received in the iss\_pk\_queue. A FIFO queuing discipline is used in both queuing modules, because the generated traffic from commercial end stations and the ISS are composed of a single priority class. Additions to this model will include a priority-based queuing scheme based on QoS specifications for packet streams.

The meo\_proc processing module then performs shortest-path routing and forwards the packet to next-hop satellite or destination ground station. This is done based on the value in the “destination address” (see Packet Formats section) field. From the destination address of the end-user terminal, the satellite determines the closest ground station to the terminal. Continuous location monitoring allows the satellite to know if it is currently in line-of-sight of the destination ground gateway. If so, the satellite downloads the packet to the destination ground gateway. Otherwise, it forwards the packet to one of its neighboring satellites based on Dijkstra’s shortest-path algorithm, or destroys the packet if its lifetime is exceeded. The operations that every satellite node



performs include MAC-layer echo cancellation, address resolution, hop-count based lifetime control, and shortest-path routing.

The PAT subsystem performs continuous monitoring of ISS beacon signal and beacons from three GND stations to ensure correct operation. The beacon\_tx\_proc module on each satellite continuously transmits low bit rate beacon packets to the ground gateways and to the ISS. Beacon signals that are received from the ISS and each of the three ground gateways is analyzed for signal strength. The MEO-GND handoff subsystem monitors the signal strengths and implements hard handoff between GND stations.

Once\_proc is responsible for initializing state variables, model attributes and process attributes, and maintains the integrity of the node model over multiple simulation runs. Once the satellites are modeled as ATM switches, IP protocol implementation at satellite nodes allows us to perform IP-level routing. The IP-over-ATM problem is already a well-known problem with many research efforts addressing various parts of the problem. At satellite nodes, IP will be limited to IP-routing component. No ARP is recommended over the satellite network, and IP-Encapsulation is not needed because the network layer is highest layer at the MEOs.

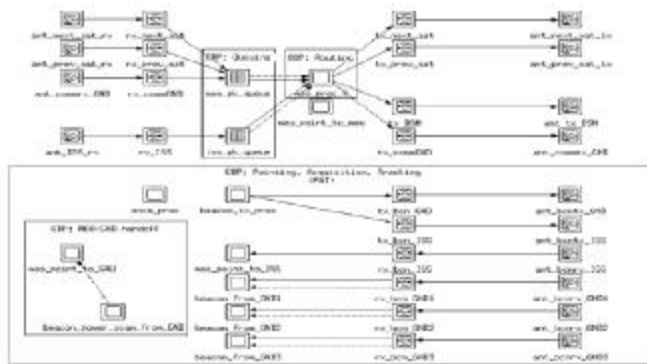

Figure 3 MEO Satellite Module

**Ground Station Module:** The simulation model currently has 3 ground stations that continuously monitor the movement of the MEO satellites to ensure correct PAT operation. Each GND station receives, from ground terminals, commercial traffic to be transmitted over satellite to other ground terminals. It also receives ISS traffic to be transmitted to ISS. GND stations also receive return traffic from the MEO network that is made up of ISS and

commercial traffic. These packets are received by the sink\_rr receiver module. Received packets are queued at the sink\_queue to be transmitted to end-users. The sink processing module uses an impartial FIFO de-queuing scheme to remove received packets from the queue and send them to one of the three end-user terminals based on the packet's destination address. All three end terminals are connected to the ground gateway using point-to-point links (pt\_0, pt\_1, pt\_2).

Point-to-point links are also used to receive data packets from the end terminals. A simple queuing model is implemented at present, with intelligence to initiate high data rate transfer of queued packets to satellite during periods of visibility. The bandwidth is shared equally between ISS packets and commercial packets in the commGND\_queue module. The commGND\_to\_sat module periodically checks for LoS to any satellite and initiates high rate transfer from the queue to the satellite.

GND\_beacon\_tx and GND\_beacon\_rx modules are responsible for the background beacon tracking operation to ensure that minimal number of data packets are lost due to small and rapidly-changing LoS windows at the ground gateway. The beacon mechanism logically links the ground gateway network with the MEO satellite network.

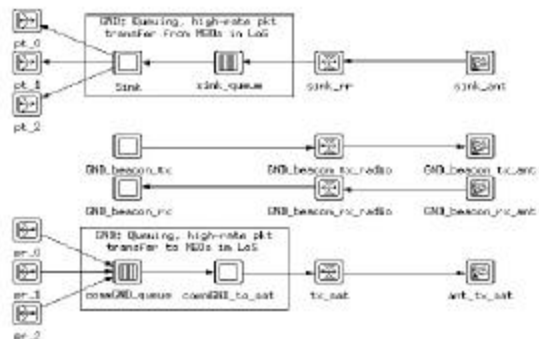
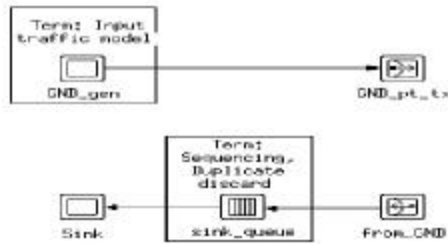

Fig 4. Node model for GND station

Advanced bandwidth allocation and queuing models can be used to partition available bandwidth between commercial traffic and ISS traffic, with the partition scheme being a test case.

**Ground Terminal/Network Gateway Module:** The network model shows 9 ground terminals that are connected to the 3 GND stations (three to each). These terminals can be considered to be network

gateways to corporate/local/wide-area networks. Each terminal acts as a source and sink for data traffic to/from other terminals and to/from the ISS. The modules GND\_gen and Sink perform these functions at the network end-user terminals.



**Fig 5 Model for ground terminal/network**

### gateway

A simple FIFO transmit queue is shared by both types of traffic. The receiver queue at network gateways performs segmentation/reassembly, MAC-layer packet sequencing, and duplicate packet detection and discarding. SAR operations are performed based on the packet's sequence number. Packet sequencing operations are carried out using an internal queue called the overflow queue, which stores packets that are received out of order. If a packet's sequence number is less than expected, it is discarded as a duplicate. If the sequence number is greater than expected, it is inserted into the overflow queue and the queue is sorted using a bubble-sort technique. The head of the overflow queue is then checked to see if it is the packet with the expected sequence number. This operation is performed in the sink\_queue process model.

Improved traffic models are planned at transmitters to model multiple traffic types for different service classes and QoS requirements. IP (or other network-layer) protocol and basic TCP implementation to provide support for end-to-end QoS guarantees for multiple services. All three IP components (IP-ARP, IP-Encapsulation and IP-Routing) will be implemented. End-to-end statistic collection, average packet delays, packet loss, queue lengths, performance for each service class and traffic type.

### Chapter 5: Simulation Model Components-GEO Constellation

In this case, model consists of similar four types of Modules described earlier. Satellite Module of GEO case however is much simpler as the network topology is very simple.

### Chapter 6: Preliminary Results & Discussion

Since we are dealing with a preliminary model at this early stage, we are not yet able to run detailed end-to-end performance simulation runs, so the information we can get at this stage is limited. However, we are currently able to look at some proof of concept runs and verify the correct operation of the different components in the network.

Fig. 6 plots the average queuing delay at each GND station. Fig. 7, plots the queue length over a fixed time interval over selected satellites. It shows the variation in load of each satellite. Note that the load on each satellite in this simulation model will converge to the mean over multiple revolutions. Over a single revolution the values will not converge, as the orbital period of the ISS is not a multiple of the orbital period of the MEO network.

### Chapter 7: Coverage Analysis

We next turn our attention on some preliminary coverage analysis for two different constellations, using Orblink as the example for the MEO case and Spaceway [4] as the example for a next generation GEO commercial system. The following assumptions apply to the two scenarios we investigate, using the STK package. Note that these are simplifying assumptions to provide an initial frame-of-reference and do not represent the particular details of the system design for the two constellations, since much of that information is not available in the public domain:

- Satellite antenna is fixed (pointing nadir), and 90-deg cone angle
- Line-of-sight is assumed for access at the satellites (no elevation angle or other constraints are placed on the satellites)
- “complete chain access” means the total time during which any object within the first element in the chain has access to any object in the next and sequential elements in the chain.

We consider two scenarios:

### Chapter 8: Scenario 1 (Fixed ground antennas, variable cone angle)

- Fixed ground antennas (north-pointing)
- Variable cone angle

- Fixed elevation angle
- Fixed satellite antennas

This scenario assumes that the antenna’s position on the ground station is fixed, pointing local vertical north (90-deg elevation). The size of the cone would be the determining factor for duration of access in

this case. However, if an additional constraint was point on the antenna such as minimum elevation angle of the access, then this could impact the access time if the elevation angle enters within the mounds of the cone. So, this scenario assumes that the minimum elevation angle constraint is smaller than the complement of the cone half-angle. The data

used is given in *Table 1*.

| Cone Angle, C | ISS-SW-GN | ISS-SW-WALLO PS | ISS-OL-GN | ISS-OL-WALLO PS |
|---------------|-----------|-----------------|-----------|-----------------|
| 5             | 0         | 0               | 0         | 0               |
| 10            | 0         | 0               | 0         | 0               |
| 20            | 0         | 0               | 0         | 0               |
| 35            | 0         | 0               | 0         | 0               |
| 50            | 0         | 0               | 0         | 0               |
| 60            | 79856     | 61843           | 15397     | 15397           |

**TABLE 1: Fixed Antenna, Fixed Elev.Angle ( $e < 90 - c$ ); Variable Cone Angle**

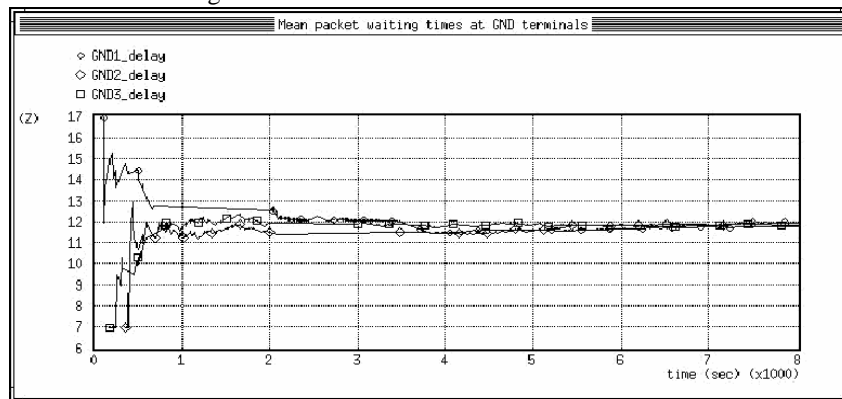

**Fig. 6 Average RX-Queueing Delay at GND stations**

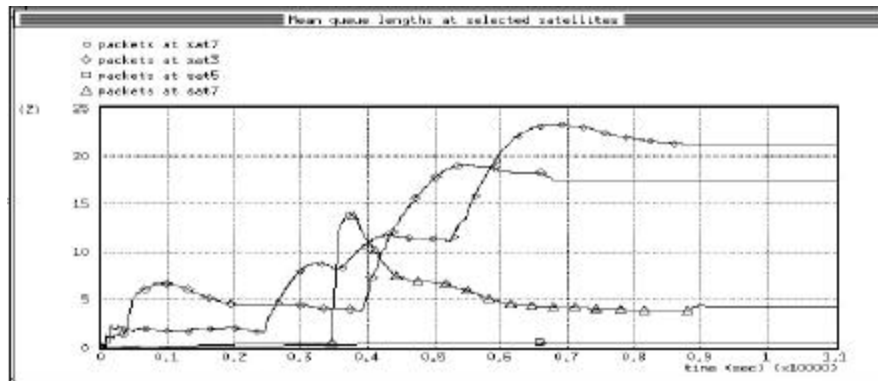

**Fig 7. Average OBP-queue lengths at MEO satellites**

It is interesting to note that in this case, the duration exhibited is similar to that of a step function – there is

no complete chain access at all unless the cone angle on the fixed ground antenna is greater than a certain

amount. This occurs because all the ground stations are at high latitudes, while both constellations have equatorial orbits (zero degree inclination). A report of the elevation angle of line-of-sight access from the ground station closest to the equator, Wallops, to the Spaceway constellation is about 38.1 deg. This means that if the antenna was north-fixed, the minimum half-cone angle needed for even the best-located facility would be  $90 - 38.6 = 51.4$  deg. The minimum half-cone angle needed for the best-located facility to access orblink is  $90 - 31.4 = 58.6$  deg. In general, satellites at greater altitudes (such as Spaceway) have less geometric constraints than those at lower altitudes (such as Orblink).

**Chapter 9: Scenario 2 (Tracking antennas, variable elevation angle)**

Tracking ground antennas (targeted on constellation)

- Variable elevation angle
- Fixed cone angle
- Fixed satellite antennas

| Elev Angle, e | ISS-SW-GN | ISS-SW-WALLO PS | ISS-OL-GN | ISS-OL-WALLO PS |
|---------------|-----------|-----------------|-----------|-----------------|
| 0             | 79856.71  | 61483.33        | 80418.19  | 55219.20        |
| 10            | 79856.71  | 61483.33        | 70889.31  | 48852.77        |
| 15            | 79856.71  | 61483.33        | 63566.43  | 44964.2         |
| 20            | 79856.71  | 61483.33        | 43534.15  | 41463.08        |
| 30            | 79856.71  | 61483.33        | 15397.08  | 15397.09        |
| 35            | 61843.32  | 61483.33        | 0         | 0               |
| 50            | 0         | 0               | 0         | 0               |

**TABLE 2: Tracking Antenna, Fixed Cone.Angle (5 deg min); Variable Elevation Angle**

For the case in which the antennas on the ground station are allowed to rotate and track the commercial satellite during the period which there is acquisition, the antenna by definition moves as to maintain the satellite along the boresight of the antenna. In this situation, the cone angle of the ground antenna is not important; for as long as the center of the antenna has line of sight to the satellite, there is contact. The minimum allowable elevation angle, however, will

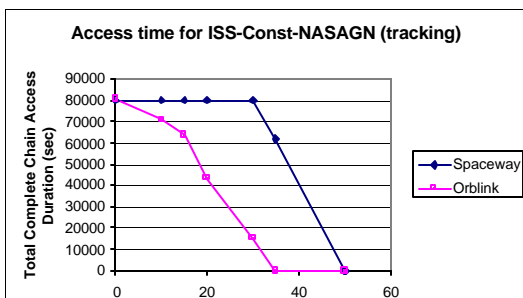

directly restrict the amount of access obtained. In this scenario, the minimum elevation angle constraint will be varied from 0 to 50 deg. (Table 2).

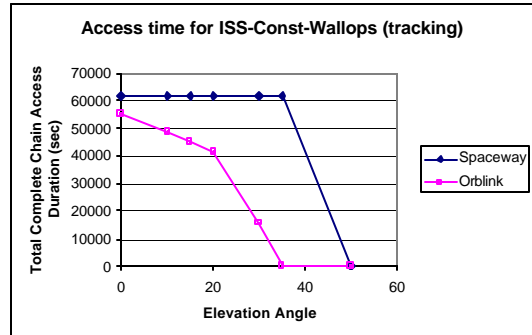

**Figure 8 Access Time Duration Vs**

**Elevation Angle**

As can be seen from the graphs and as discussed earlier, constellations with higher altitude will generally have better coverage. In this case, the distribution of the facilities were such that the total duration did not vary until a certain elevation angle, at which the duration drastically drops. We see the interesting properties of having two constellations that are both equatorial, but differ by altitude.

As can be seen from the graphs and as discussed earlier, constellations with higher altitude will generally have better coverage. In this case, the distribution of the facilities were such that the total duration did not vary until a certain elevation angle, at which the duration drastically drops. We see the interesting properties of having two constellations that are both equatorial, but differ by altitude.

**Chapter 10: COMMUNICATION SUPPORT FOR OTHER NEAR-EARTH MISSIONS**

The ISS is the top priority NASA mission at the moment, and the one with the greatest demand for broadband communication support. However, a number of other near-earth missions need to be supported as well, with varying coverage and data requirements. We next turn our attention on an initial study on the coverage issues that need to be addressed in these cases. We study examples of missions in various altitudes and inclinations, and investigate the use of three proposed satellite constellations for this purpose. It is important to note that these represent the final implementations of the

complete constellations as they were described in recent FCC filings. These systems are under development and are undergoing significant changes, and will probably be implemented in several phases. The analysis presented here is only used to demonstrate the methodology and a frame of reference; a detailed modeling of a lot of proprietary details of the final designs needs to be used for a precise and more realistic evaluation of the suitability of these systems for this service. We also like to point out that systems that reach an arrangement with NASA to support mission communications will probably accommodate design modifications that would allow them to focus on this task and meet the required quality of service and coverage. The commercial systems considered here are:

**Spaceway:** The Spaceway constellation consists of 20 geo-synchronous satellites at 15 positions. For the sake of this analysis, this system is represented with 15 satellites with one at each of the longitudinal positions: 101° W, 99° W, 67° W, 49° W, 25° E, 36° E, 41° E, 48° E, 54° E, 101° E, 132° E, 149° E, 164° E, and 173° E. The constellation is designed to provide coverage over populated land areas, so the longitudinal positions of the satellites are not evenly distributed, and instead are chosen to provide more land coverage.

The instruments on the satellites in actuality consist of 183 spot beams with a 1.5° field-of-view per beam. Because each satellite is stationary relative to the earth, each beam can be individually pointed to target certain areas on the earth. Because information on the pointing of each individual beam is currently not known, we approximate them with one conic sensor on each satellite with a 7° half-cone angle pointing nadir (towards the center of the earth).

**Astrolink:** The Astrolink constellation consists of 9 geo-stationary satellites in 5 orbital positions, at 97° W, 21.5° W, 130° E, 2° E, and 175° E. For this analysis, the only the satellites with the 5 unique orbital positions were used. The antenna is assumed to have a 5° half cone angle pointing fixed at the center of the earth.

**Orblink:** The Orblink constellation consists of 7 satellites at an altitude of 9,000 km following an

equatorial orbit (zero degree inclination). This constellation is approximated in this analysis with an even distribution of satellites around the equator. The antenna on each satellite is assumed to have a 24° half-cone angle pointed fixed towards the center of the earth.

**Chapter 11: Static Coverage Analysis**

For each satellite constellation, static coverage analysis was performed by fixing an arbitrary moment in time, and determining the percentage of the earth that has access to one or more of the commercial satellites. This analysis was then repeated for space mission altitudes of 300 km and 700 km. Generally, reduction in percentage of coverage is seen with increasing altitude. Commercial constellations that are low in altitude (such as Orblink) will usually be more susceptible to changes in the NASA user’s altitude than constellations higher in altitude. Figure 9 shows the changes in coverage for the Orblink example, for three different mission altitudes.

**Chapter 12: Dynamic Coverage Analysis**

This analysis shows the dynamic geometric coverage as the NASA user satellite and commercial satellite constellation are both moving over a period of time. Results are obtained by running the scenario for a 10-day period at 60-second step sizes. One continuous coverage is defined as the period of time that the NASA satellite is in field-of-view with one or more of the sensors on the commercial satellites. Repeated trials were performed for each commercial constellation, with varying cases for the NASA user satellite. Results are listed in Table 3.

Figure 10 shows an example of the type of analysis of these results we can use to determine percentage of coverage and the effect of the mission altitude and inclination angle on coverage by the three constellations. These could then be translated to type of services that can be supported and maximum durations of these services, based on the coverage duration, as well as scheduling of services based on the mission location with respect to the satellite constellation and the ground.

|                               |                                     |                                     |                                     |                                   |                                     |                                     |
|-------------------------------|-------------------------------------|-------------------------------------|-------------------------------------|-----------------------------------|-------------------------------------|-------------------------------------|
| <b>SPACEWAY<br/>Parameter</b> | <b>Case 1: 300<br/>km, 28.5 deg</b> | <b>Case 2: 500<br/>km, 28.5 deg</b> | <b>Case 3: 700<br/>km, 28.5 deg</b> | <b>Case 4: 500<br/>km, 57 deg</b> | <b>Case 5: 700<br/>km, 98.2 deg</b> | <b>Case 6: 400<br/>km, 51.5 deg</b> |
|-------------------------------|-------------------------------------|-------------------------------------|-------------------------------------|-----------------------------------|-------------------------------------|-------------------------------------|

|                                |       |       |       |      |      |        |
|--------------------------------|-------|-------|-------|------|------|--------|
| Coverage Percent               | 90.8  | 88.3  | 85.9  | 47.9 | 36.4 | 55.5   |
| Coverage Time                  | 13081 | 12709 | 12367 | 6892 | 5243 | 7986.8 |
| Continuous coverage, ave (min) | 46.6  | 44.4  | 45.5  | 21.9 | 19.5 | 23     |
| Continuous coverage, max (min) | 91.2  | 57.5  | 59.1  | 27.3 | 22   | 30.4   |
| <b>ORBLINK Parameter</b>       |       |       |       |      |      |        |
| Coverage Percent               | 100   | 100   | 100   | 54.1 | 39.7 | 64.7   |
| Coverage Time                  | 14400 | 14400 | 14400 | 7793 | 5720 | 9321   |
| Continuous coverage, ave (min) | 14400 | 14400 | 14400 | 25.6 | 19.6 | 29.7   |
| Continuous coverage, max (min) | 14400 | 14400 | 14400 | 27   | 20.8 | 31.6   |
| <b>ASTROLINK Parameter</b>     |       |       |       |      |      |        |
| Coverage Percent               | 45.4  | 40.5  | 36.9  | 19.6 | 15.3 | 22.2   |
| Coverage Time                  | 6545  | 5833  | 5317  | 2828 | 2203 | 3191   |
| Continuous coverage, ave (min) | 12.1  | 12.9  | 13.5  | 12.8 | 11.8 | 13     |
| Continuous coverage, max (min) | 24.5  | 25    | 25.5  | 17.1 | 14.2 | 18.8   |

*Table 3*

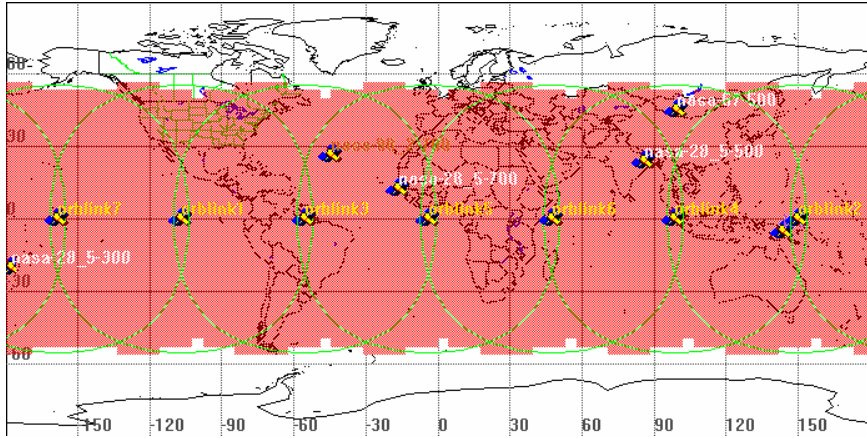

**Figure 9a Orblink Static Coverage for mission at 0 km (80%)**

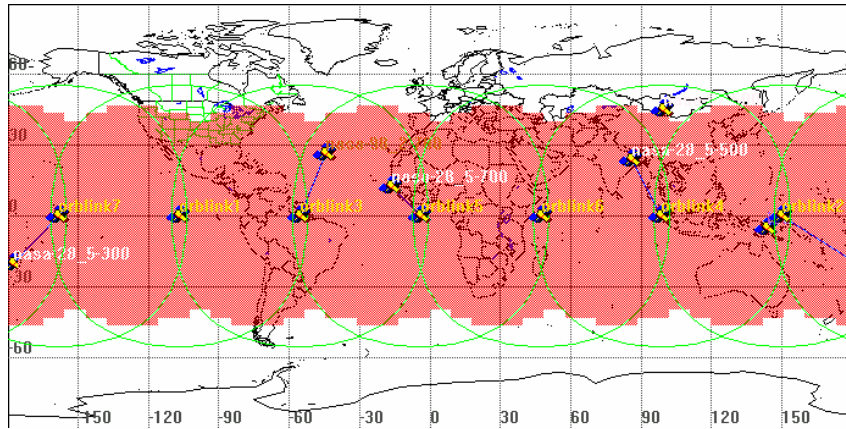

**Figure 9b Orblink Static Coverage for mission at 300 km (68.6%)**

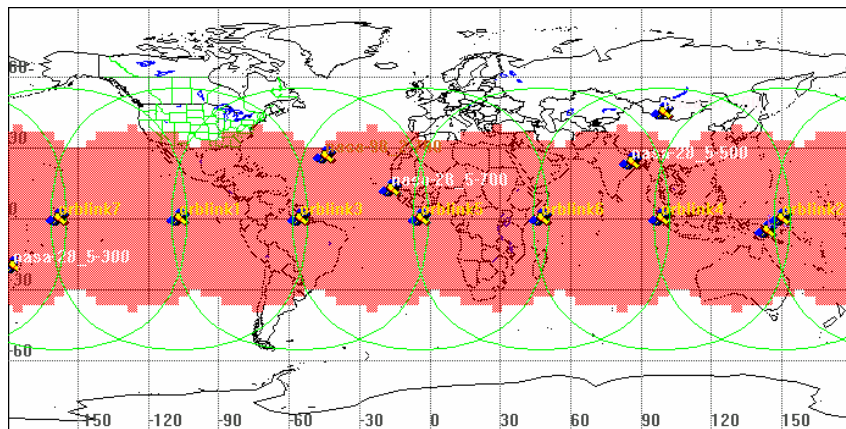

**Figure 9c Orblink Static Coverage for mission at 700 km (57.9 %)**

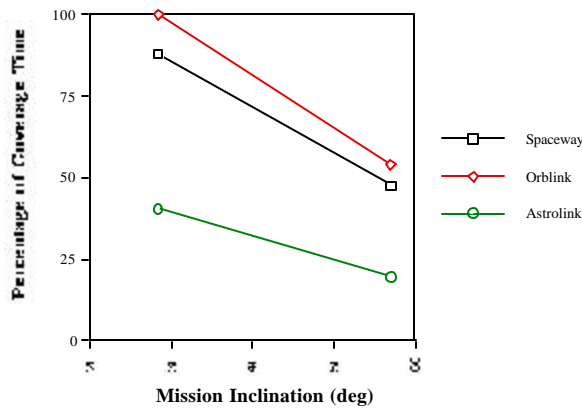
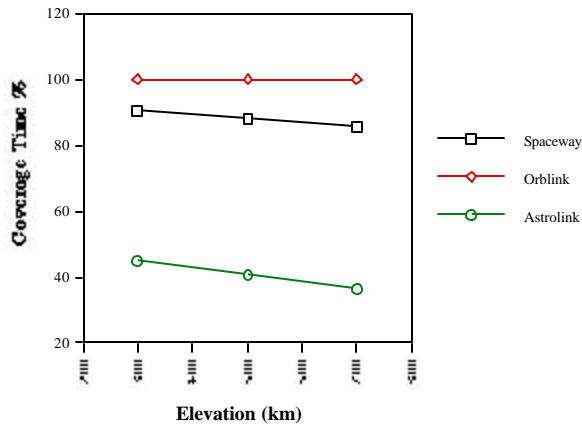

**Figure 10** Effect of mission altitude(elevation) and inclination on coverage

**Chapter 13: SUMMARY & FURTHER WORK**

We are developing a methodology and a large-scale simulation model to evaluate the feasibility of carrying NASA mission payload, command and control, real-time and low-priority data between ground user terminals and near-earth spacecraft, using proposed commercial satellite constellations. The simulation model will allow us to perform detailed studies to quantify the performance of satellite systems for the following test parameters: specific services and their QoS requirements,

protocols, traffic models, satellite routing schemes, on-board bandwidth/buffer allocation methods, queuing disciplines, and handoff strategies.

We have explained some of the features of the present models. Test modules will next be developed independently, to simulate the operation of each test case bandwidth assignment algorithms, routing algorithms, coverage issues and handoff schemes. This will enable us quantify and analyze the end-to-end performance for specific data services. The next two major steps in this work will be in modelling the data services and statistics of the traffic that must be supported as well as the protocol modifications that will allow these services to be supported.

**References**

1. Christ, U., Schultz, K.J., “Multimedia Services for Interactive Space Mission Telescience”, ESA Bulletin 96, Nov. 1998, pp. 63-69
2. Budinger, J. “NASA’s Use of Commercial Satellite Systems-Concepts and Challenges” Proc. NASA Workshop on Satellite Networks, pp. 103-112.
3. Giffin, G., Bravman, J. “Infrastucure on Demand - Global Fibre Optic Capacity from EHF Satellite Communication Systems”, Proc. Workshop on Satellite Communications and the GII, Ottawa, June 1995.
4. Fitzpatrick, E.J., “Spaceway system summary” Space Communications Vol. 13, pp. 7-23, 1995.

**Acknowledgements**

*This work is supported by the Center for Satellite and Hybrid Communication Networks, under NASA cooperative agreement NCC3-528.*

*OPNET Modeler from MIL3 was used for the network simulations.*

*STK from Analytical Graphics was used for the coverage/orbital simulations.*



## REFERENCES

- 
- 1 Hadjitheodosiou, M., Nguyen, A., "Commercial Communication Satellite Constellations Carrying Traffic From NASA Missions", Proc. 18th AIAA Intern. Conference on Satellite Systems & Communications, Oakland, CA, April 2000.
  - 2 Hadjitheodosiou, M., Nguyen, A., "Extending IP Services to Space Missions", Proc. 19th AIAA ICSSc, Toulouse, France, April 2001.
  - 3 Nguyen, A.T., Zhou, x., Hadjitheodosiou, M., Baras, J.S., "A direct-to-ground architecture for supporting Commercial Communications from the International Space Station" Submitted, IEEE ICC 2002, New York, NY, Apr. 2002.
  - 4 NASA, "TDRS H,I,J S/C and Payload Characteristics"  
<http://nmsp.gsfc.nasa.gov/tdrss/hijchar.html>, 2000
  - 5 NASA, "TDRS Antennas" <http://nmsp.gsfc.nasa.gov/tdrss/ant.html>
  - 6 NASA, "TDRS-H,I,J" <http://nmsp.gsfc.nasa.gov/tdrss/services.html>, 2000
  - 7 NASA, "Structure and Evolution of the Universe"  
[http://pao.gsfc.nasa.gov/gsfcc/earth/tdrs/tdrs\\_h.htm](http://pao.gsfc.nasa.gov/gsfcc/earth/tdrs/tdrs_h.htm)
  - 8 E. Lutz, M. Werner, A. Jahn, *Satellite Systems for Personal and Broadband Communications*. Springer, 2000
  - 9 Stanyard, Roger. "Ka-band Report". Spotbeams Communications, 1997
  - 10 De Neufville, Richard. *Applied Systems Analysis Engineering Planning and Technology Management*. McGraw-Hill, Inc. 1990.
  - 11 Space Station Imaging Corporation, "Spacestationimaging",  
<http://www.gottfriedinternational.com/spacestationimaging.htm>
  - 12 Larson, Wiley J. and Wertz, James R. *Space Mission Analysis and Design, second edition*. Microcosm, Inc. (Torrance: 1992).
  - 13 SAIC, "Duplex Direct Data Distribution System", Draft. SAIC, 2001.
  - 14 Tasaki, Keiji, Code 451, NASA Goddard Space Flight Center telephone call
  - 15 E. Lutz, M. Werner, A. Jahn, *Satellite Systems for Personal and Broadband Communications*. Springer, 2000

---

16 Tasaki, Keiji, Code 451, NASA Goddard Space Flight Center telephone call

17 Hadjitheodosiou, M., Nguyen, A., "Commercial Communication Satellite Constellations Carrying Traffic From NASA Missions", Proc. 18th AIAA Intern. Conference on Satellite Systems & Communications, Oakland, CA, April 2000.

18 Hadjitheodosiou, M., Nguyen, A. "Novel Ways to Provide Communication Support for Future Space Missions", Proceedings of GLOBECOM2000 Symposium on Satellite Communications for the New Millennium, San Francisco, Nov, 2000.

19 Hadjitheodosiou, M., Nguyen, A, "Extending IP Services to Space Missions", Proc. 19th AIAA ICSSc, Toulouse, France, April 2001.

20 Nguyen, A.T., Zhou, x., Hadjitheodosiou, M., Baras, J.S., "A direct-to-ground architecture for supporting Commercial Communications from the International Space Station" Submitted, IEEE ICC 2002, New York, NY, Apr. 2002.