

ENCE 353: An Overview of Structural Analysis and Design

Mark Austin

Spring Semester 2026

Outline

- Objectives of Structural Engineering
- A little history
- Structural Engineering Process
- Types of loads
- Types of structures
- Civil Engineering Materials
- Load paths in structures
- How can structures fail?
- Summary



Objectives of Structural Engineering

Structural engineering is ...

... the field of engineering particularly concerned with the design of economical and efficient load-bearing structures.

Within civil engineering, it is largely ...

... the implementation of mechanics to the design of the large structures that are fundamental to basic living, such as buildings, bridges, walls, dams, and tunnels.

Structural design is ...:

... the process of determining location, material, and size of structural elements to resist forces acting in a structure

Objectives of Structural Engineering

- Structural engineers need to design structures that ...
- ... do not collapse or behave in undesirable ways while serving their useful functions.
- The efficient use of funds and materials to achieve these structural goals is also a major concern.
- Structural engineers work closely with geotechnical engineers, architects, construction managers, and transportation engineers, ME/EE, to name only a few.

How do I become a Structural Engineer?

Apprentice structural engineers may design ...

... simple beams, columns, and floors of a new building, including calculating the loads on each member and the load capacity of various building materials (steel, timber, masonry, and concrete).

An experienced engineer would tend to design more complex structures, such as multistory buildings or bridges.

It is in the design of these more complex systems that a structural engineer must draw upon creativity -- this will be part design and part art -- in the application of mechanics principles.

A Little History

Exemplars of Early Work



- Great Pyramid of Giza, Egypt (20 year construction; finished 2556 BC).
- The Parthenon in Ancient Greece (447-438 BC).
- Construction of the Great Wall of China (220 BC).
- The Romans developed civil structures throughout their empire, including especially aqueducts, insulae, harbours, bridges, dams and roads.

A Little History

Leaning Tower of Pisa (12th Century)



- Designed to be the **tallest bell tower in Europe**.
- Construction: Three stages over 199 years (1173-1372).
- Constructed from **white marble**.
- Tower leans because of **weak unstable subsoil**.
- It once leaned at 5.5 degrees.
- Currently leans at 3.99 degrees.
- Has **survived 4 earthquakes** –ironically, weak subsoil conditions work to **protect** Pisa from ground accelerations.

A Little History

Year	Milestone
1854	Bessemer invents steel converter.
1849	Monier develops reinforced concrete.
1863	Siemens-Martin open hearth process makes steel available in bulk.

1848 (approx).



1888



A Little History

Early Skyscrapers

Skyscrapers (1890s) create habitable spaces in tall buildings for office workers.

Enablers	Example: Empire State Building
<ul style="list-style-type: none">● New materials → design of tall structures having large open interior spaces.● Elevators (1857) → vertical transportation building occupants.● Mechanical systems → delivery of water, heating and cooling.● Collections of skyscrapers → high-density CBDs/commuter society.	

A Little History

Urban Development in NYC



Urban Development in Shanghai



Challenges (2020-2060)

Crisis in Infrastructure Investment

Exemplars of Work from the 1800s and 1900s

From the 1800s	From the 1900s
Erie Canal (1825)	New York City Subway (1904)
Transcontinental Railroad (1869)	The Panama Canal (1914)
Brooklyn Bridge (1883)	Holland Tunnel (1927)
Washington Monument (1884)	Empire State Building (1931).
	Hoover Dam (1936).
	Golden Gate Bridge (1937)
	Interstate Highway System (1956)

Source: Celebrating the Greatest Profession, Magazine of the American Society of Civil Engineers, Vol. 72, No. 11, 2002.

Crisis in Infrastructure Investment

Universal Observations:

- Aging infrastructure becomes expensive to maintain.
- New (replacement) infrastructure is very expensive.
- Politicians are eager to talk up Infrastructure Investment , but slow to deliver

Bottom line:

- Critical infrastructure is taken for granted and not a national priority (ASCE, IEEE).

Delay, delay, delay

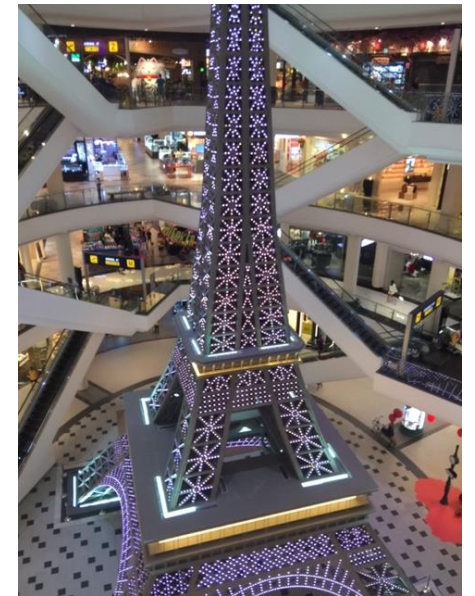

Bangkok, Thailand

Poster Child: Collapse of the Minneapolis bridge over 135W.



The 40-year old steel deck truss crossing had been considered **structurally deficient since 1990**, but engineers with the Minnesota Department of Transportation had **not believed** the bridge to be in danger of **imminent collapse**.

Thirteen commuters were killed and more than 100 were injured on August 1, 2007.

Crisis in Infrastructure Investment

Statistics:

- US: Post World-War II (1950-1970): 3% of Gross Domestic Product (GDP)
- US: 1980-present: 2% of GDP.
- China: 5% GDP.
- India: 9% GDP.

United States GDP

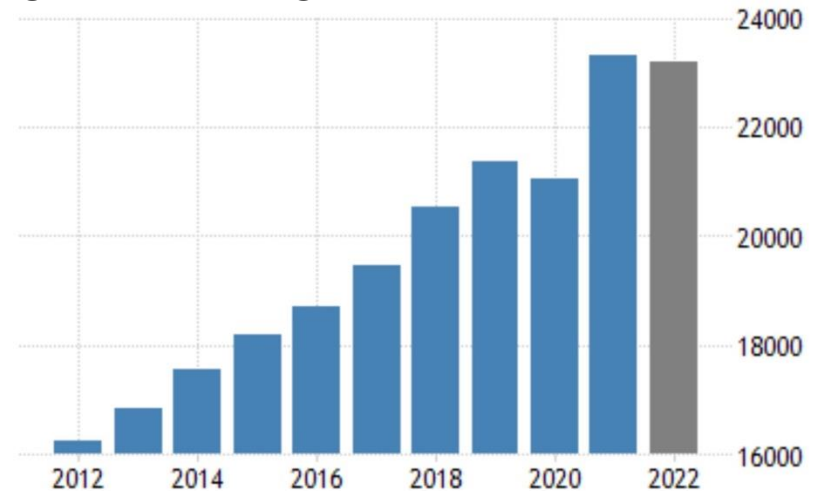

Infrastructure Investment and Jobs Act (2021).

- Invest \$1.2T over 10 years.
- Sounds like a lot – but is it too low, too high?
- Increases investment by 0.5% of GDP.

US Employment 1939-present

1800s to early 1900s
40% of Americans
 Worked in Agriculture

**U.S. Employment
 1939 - Present**
 (Recessions in Blue)
www.UnemploymentData.com
 Updated 10/4/2024

8% of Americans
 Work in Manufacturing
 & **2%** work in Agriculture

**The Invention of
 Mechanisation &
 Electrification**

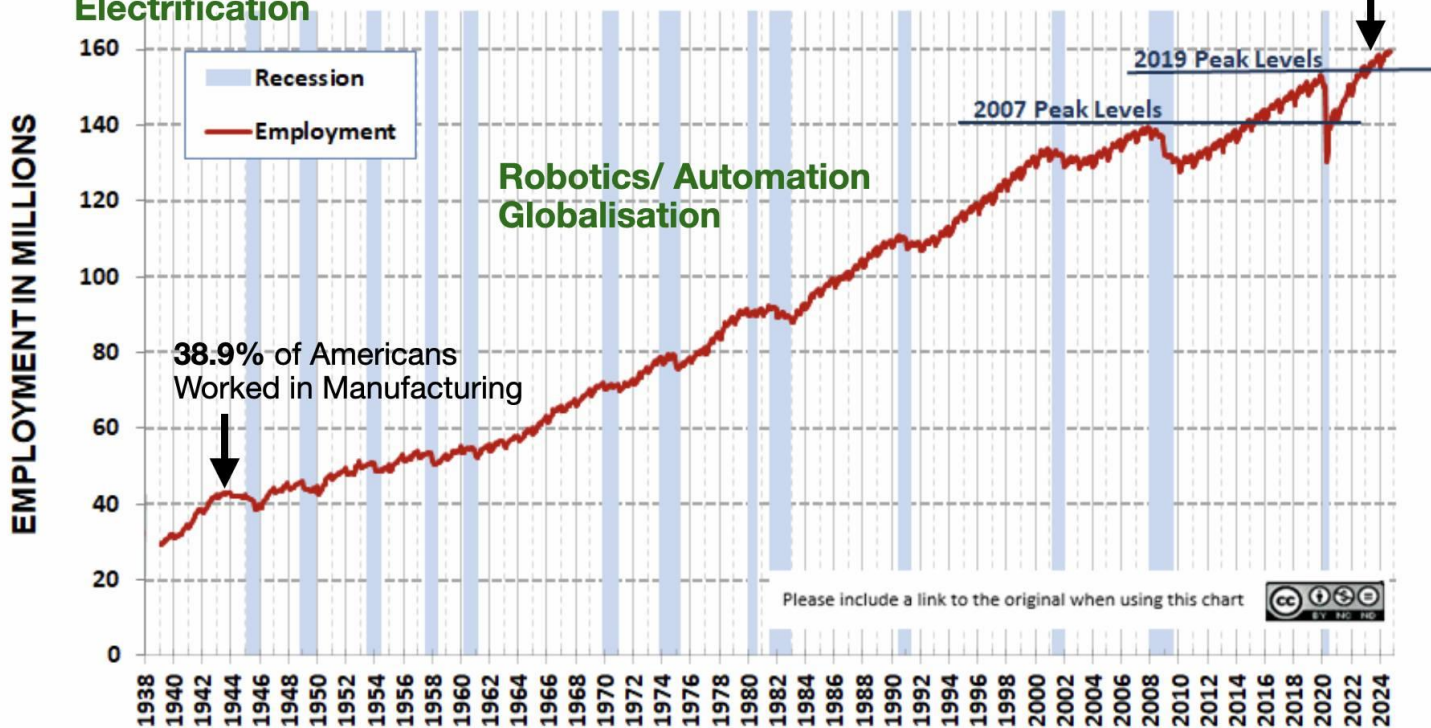

Source: U.S. Bureau of Labor Statistics- Total Non-Farm Employment Not Seasonally Adjusted
 Series CEU 0000000001 Recessions per National Bureau of Economic Research (NBER)

Looking Ahead

World population growth

Fertility rates are declining, the United Nations says, but not fast enough to stop population growth. The U.N.'s medium-level projection is for the world's population to reach 9.2 billion by 2050 but still more than 3 billion higher since the turn of the century. Population activists say that's too much for the world to handle.

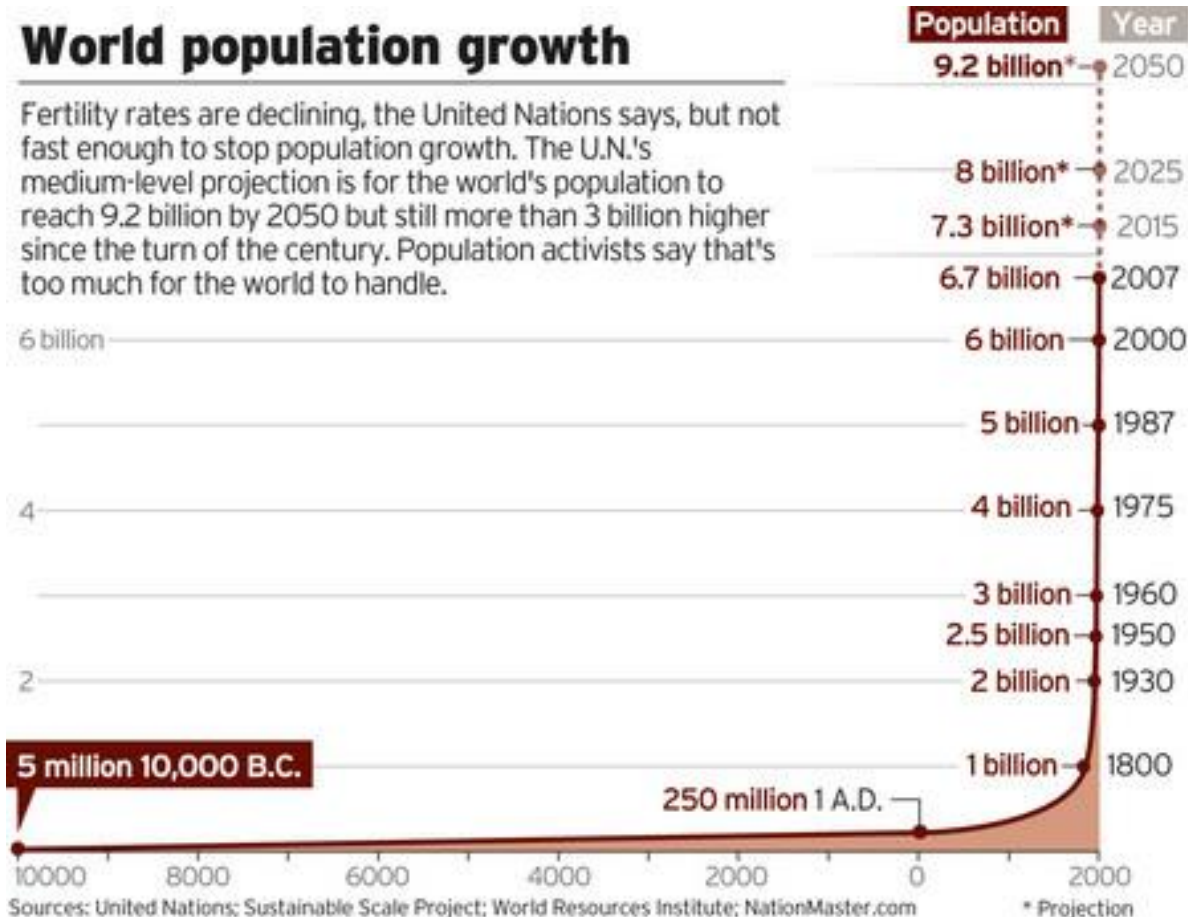

Increasing Population → Increased Demand on Limited Resources → Increasing need for **Improvements to System Efficiency.**

Looking Ahead

Example. Engineering Modern Skyscrapers

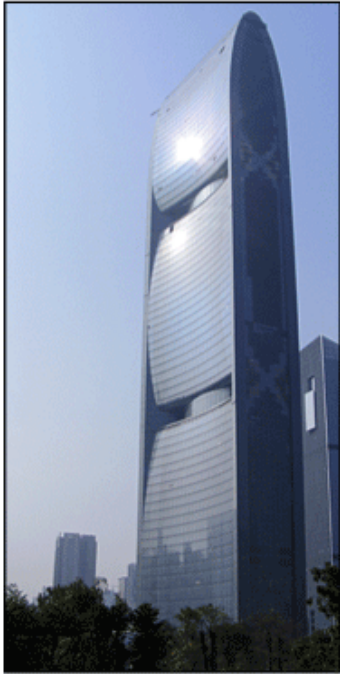
Enablers	Example: Pearl River Tower
<ul style="list-style-type: none">● High performance structure designed to produce as much energy as it consumes.● Guides wind to a pair of openings at its mechanical floors.● Winds drive turbines that generate energy for the heating, ventilation and air conditioning systems.● Openings provide structural relief, by allowing wind to pass through the building.	

Looking Ahead

Emergence of New Architectural Forms

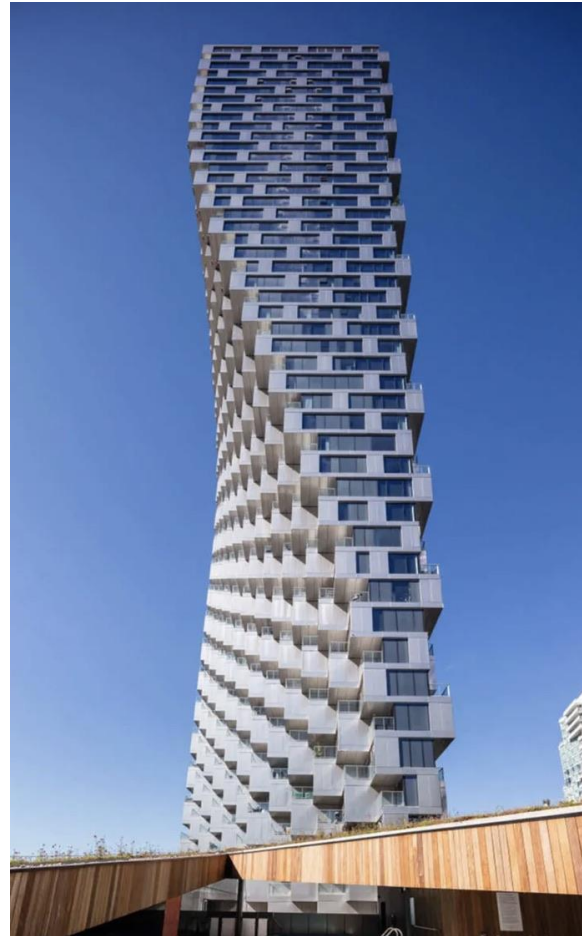
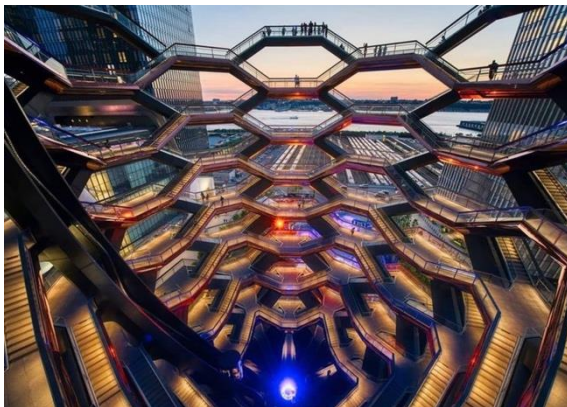

Looking Ahead

Parametric Architectural Design



Structural Design Process

Structural Design Process

- Determine types **magnitudes** of **loads and forces** acting on the structure
- Determine structural context
 - geometric and geological information
 - cost / schedule / height/ etc. limitations
- Generate **alternative structural systems** (e.g., moment resistant frame, materials selection),
- **Analyze one or more alternatives**
- Select and perform detailed design
- Implement (usually done by contractor)

Note: **New structural systems** may also require an **experimental testing** phase to **verify behavior** and **system performance**.

Formal Approach to Structural Design

Formal Approaches to Behavior Modeling and Decision Making

Appropriate formalisms depend on the design domain of interest.

- Physical aspects of behavior are often characterized by differential equations.
- Logical aspects of system design can be captured by binary and multi-valued logic variables and boolean equations.

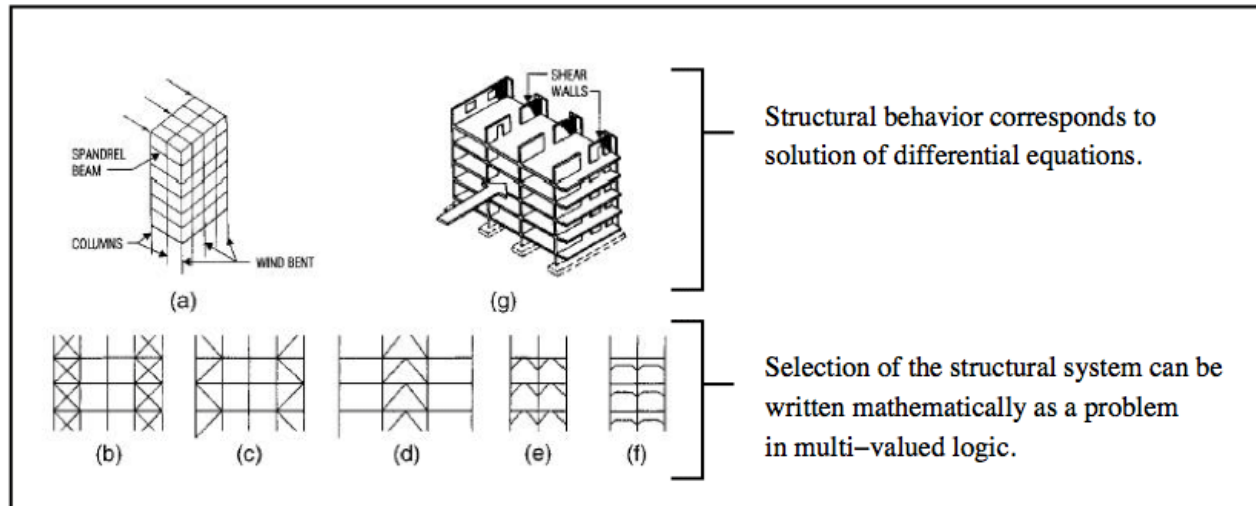

Formal Approach to Structural Design

Structural Behavior

Time-dependent behavior corresponds to solutions of:

$$[M] \frac{d^2 x}{dt^2} + [C] \frac{dx}{dt} + [K] x = P(t). \quad (1)$$

Here,

- M, C, and K are $(n \times n)$ matrices,
- x is a $(n \times 1)$ vector of displacements,
- P(t) is a vector of external loads applied to the structural degrees of freedom.

Design Parameters

- Selection of the best structural system (e.g., braced system) from a list of options.
- Size of the beams, columns, and bracing (if required).

Loads

Types of loads

- Dead loads
- Live loads
- Dynamic loads (e.g., trains, equipment)
- Wind loads
- Earthquake loads
- Thermal loads
- Settlement loads

Dead Loads

- weight of the structure itself
 - floors, beams, roofs, decks, beams/stringers, superstructure
- loads that are “always there”



Live Loads

- People, furniture, equipment
- Loads that may move or change mass or weight
- Minimum design loadings are usually specified in the building code



Dynamic Loads

- Moving loads (e.g., traffic)
- Impact loads
- Gusts of wind
- Loads due to cycling machinery



Load Example: Water in a dam

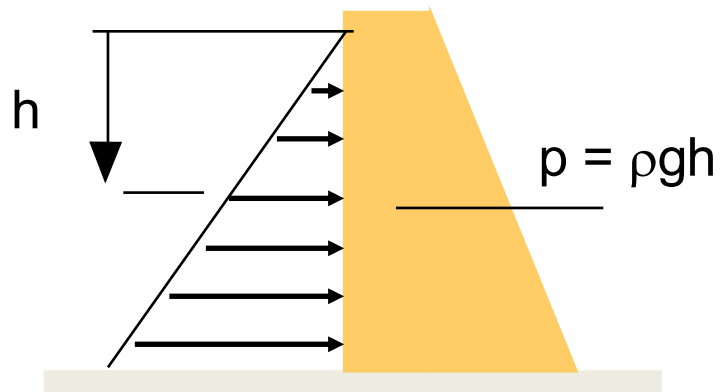
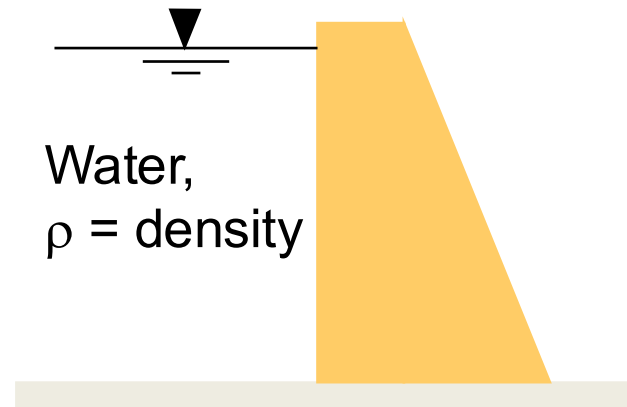

Earthquake Loads

- Structure loaded when base is shaken
- Response of structure is dependent on the **frequency content** and **magnitude** of **ground motion**.
- When frequencies of ground motion match with natural frequency of structure – **resonance** leads to **amplified displacements**.

Fixed-Base versus Base-Isolated Response

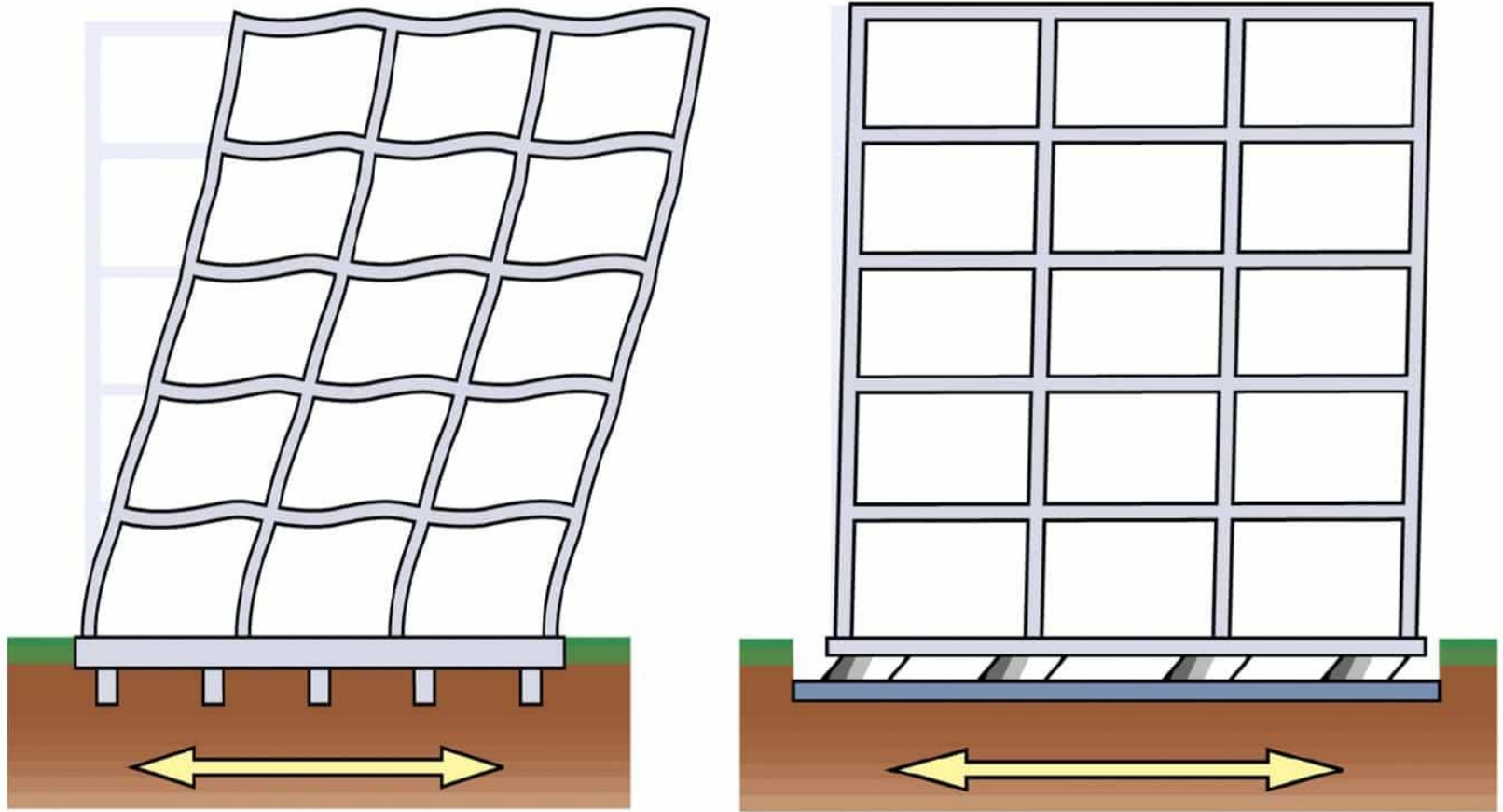

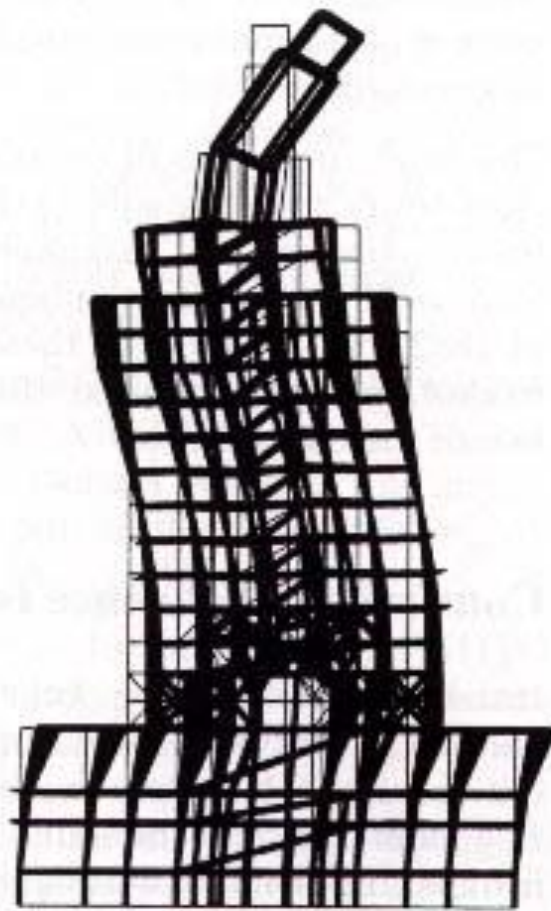

Fixed Base

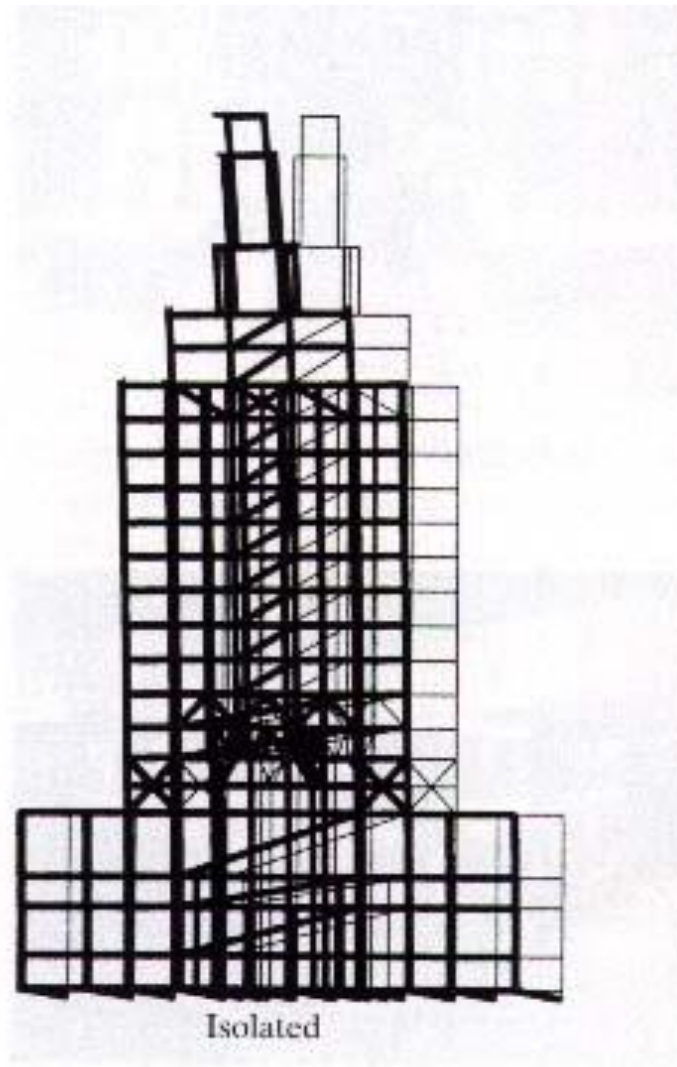

Isolated

4: Seismic response of the building

Two Applications of Base Isolation



Settlement



Note: See link on class web page to article on Settlement of Millennium Tower in San Francisco.

...structure, I accepted the appointment in spite of my advanced age, then 80. I was determined to see that the Tower survived.

The Committee was constituted as follows:

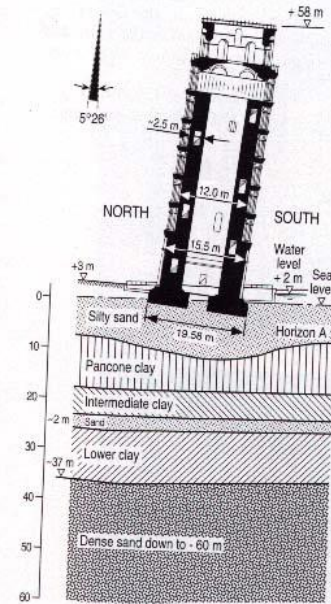

Fig. 2: Soil profile

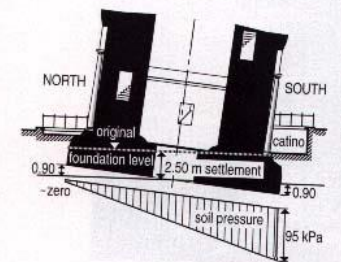
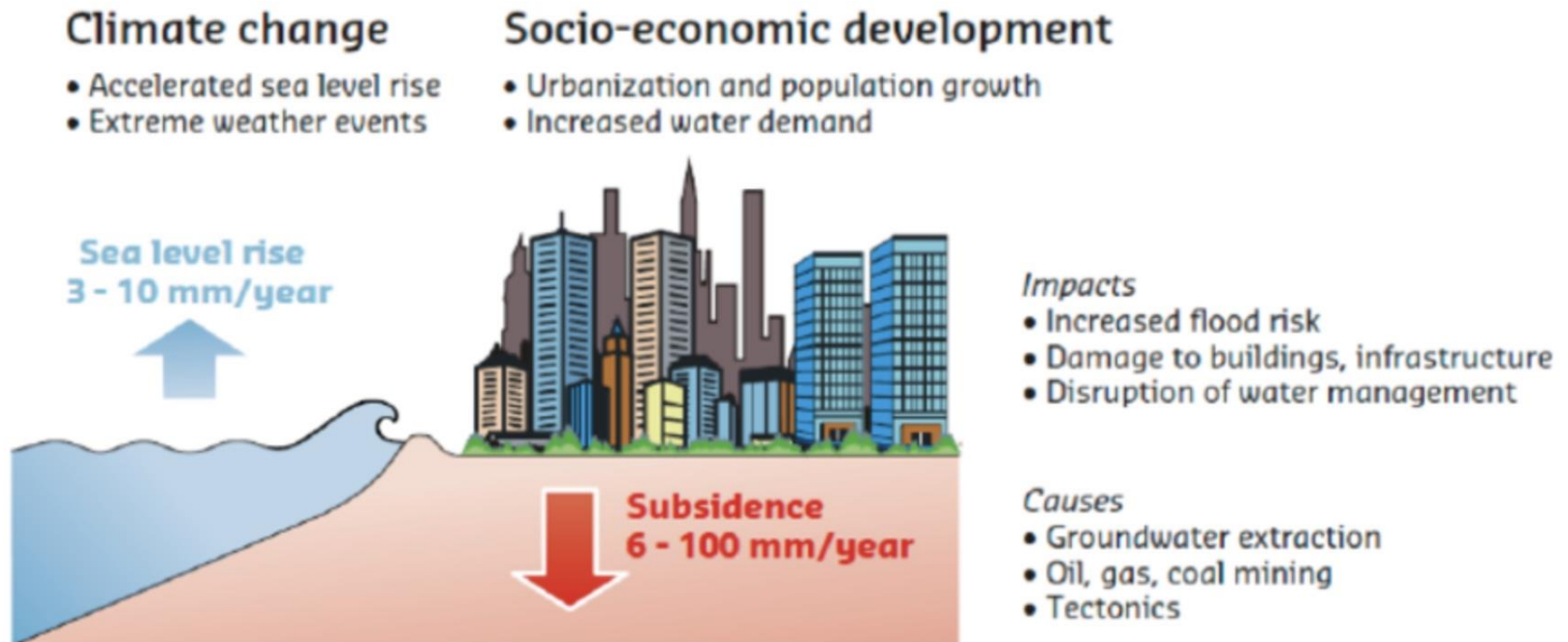

Fig. 3: Settlement and soil pressure

Sinking of Coastal Cities

Emerging problem that will cause damage to buildings and urban infrastructure, increase the risk of flooding, and disrupt water supply systems.



Forces Acting in Structures

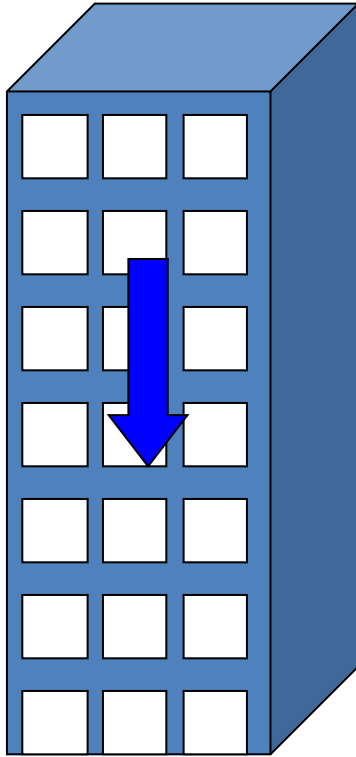

Vertical: Gravity

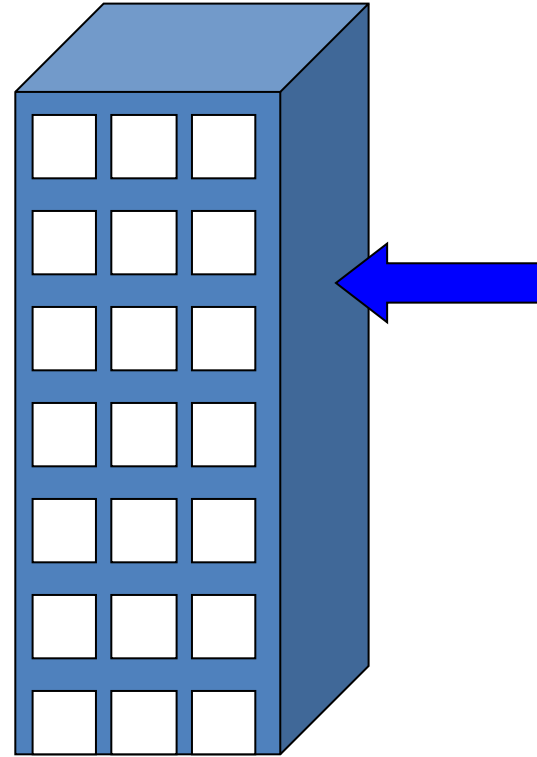

Lateral: Wind, Earthquake

Global Stability

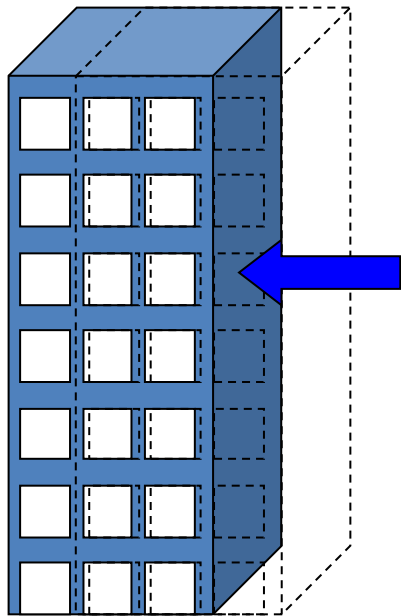

Sliding

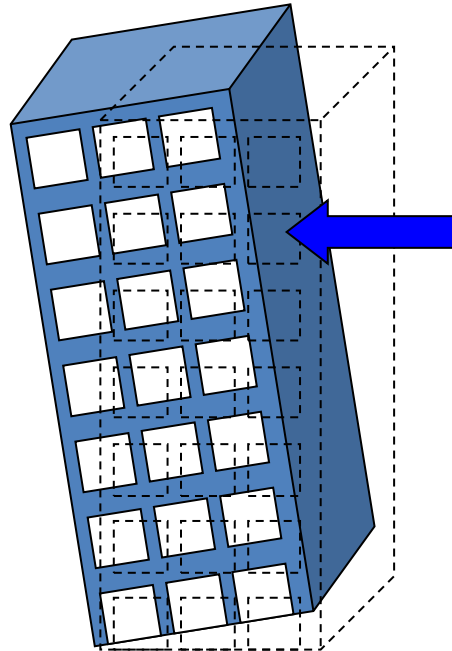

Overturning



Forces in Structural Elements

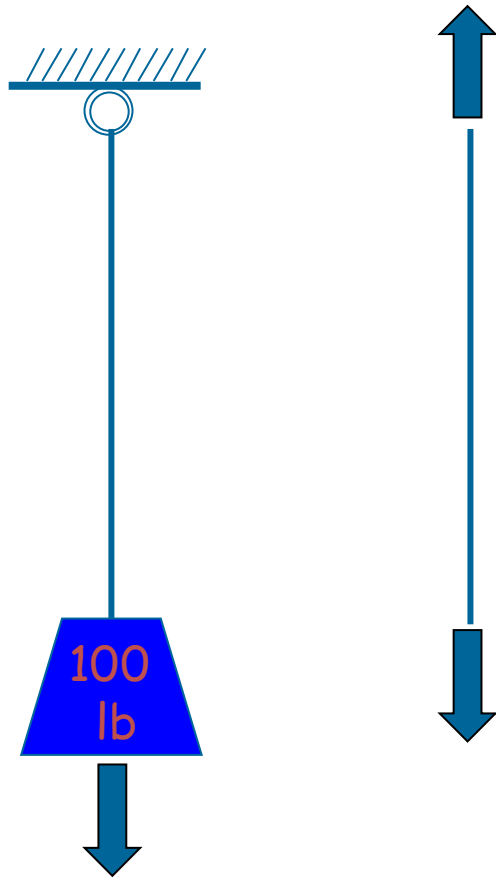

Tension

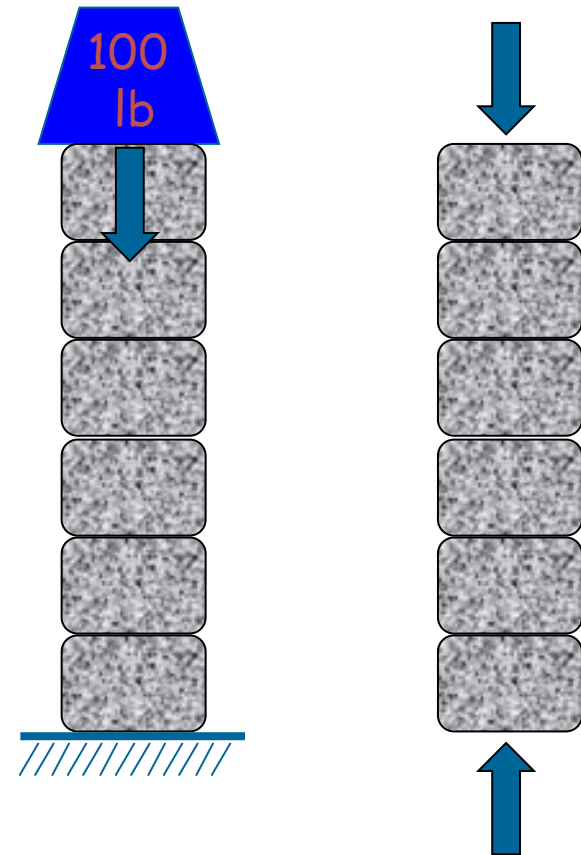

Compression

Forces in Structural Elements (cont.)

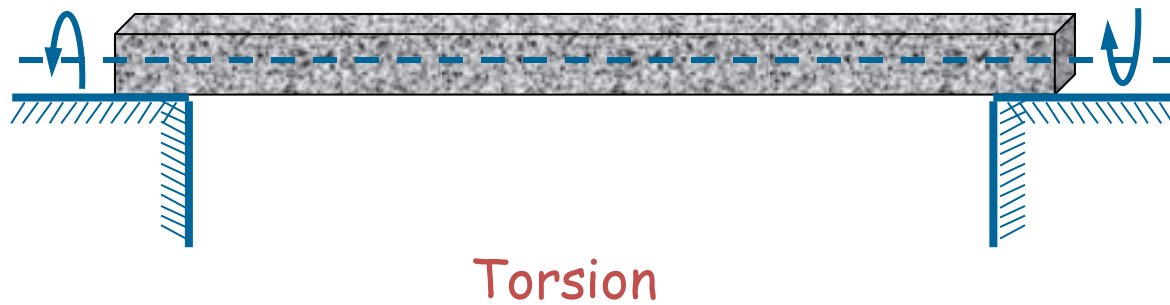
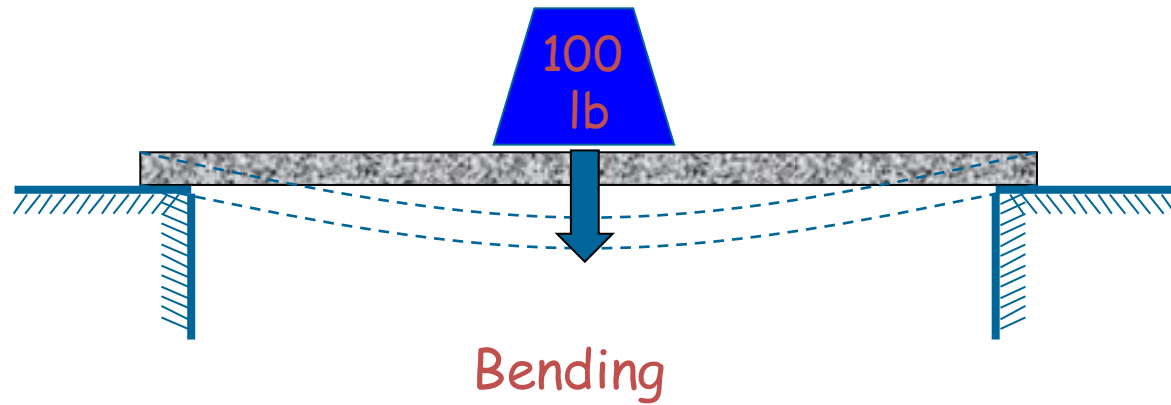

Types of Structural System

Some Types of Structures

- Arch
- Planar Truss
- Beam/Girder
- Flat plate
- Braced and Rigid Frames
- Folded Plate and Shell Structures
- Cable Suspended Structure

Arch

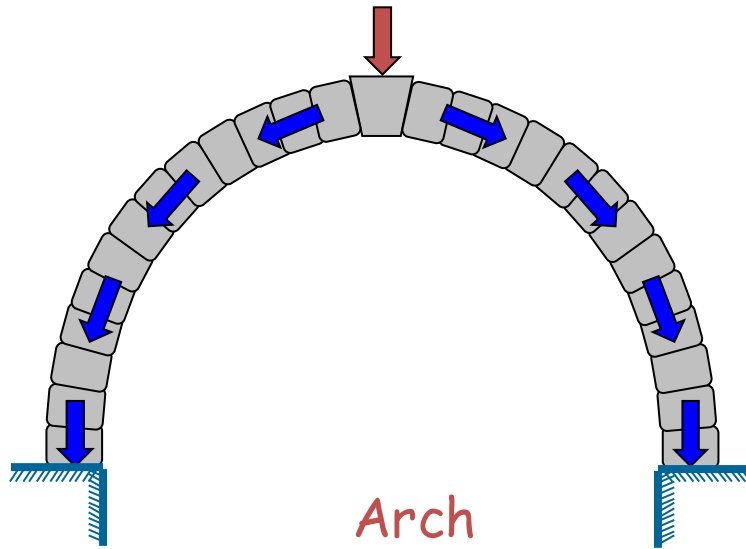

Design objective: Structure needs to work and be aesthetically pleasing!!

Analysis objective: What shape should the arch be so that forces can be transferred to the foundation through compression mechanisms alone?

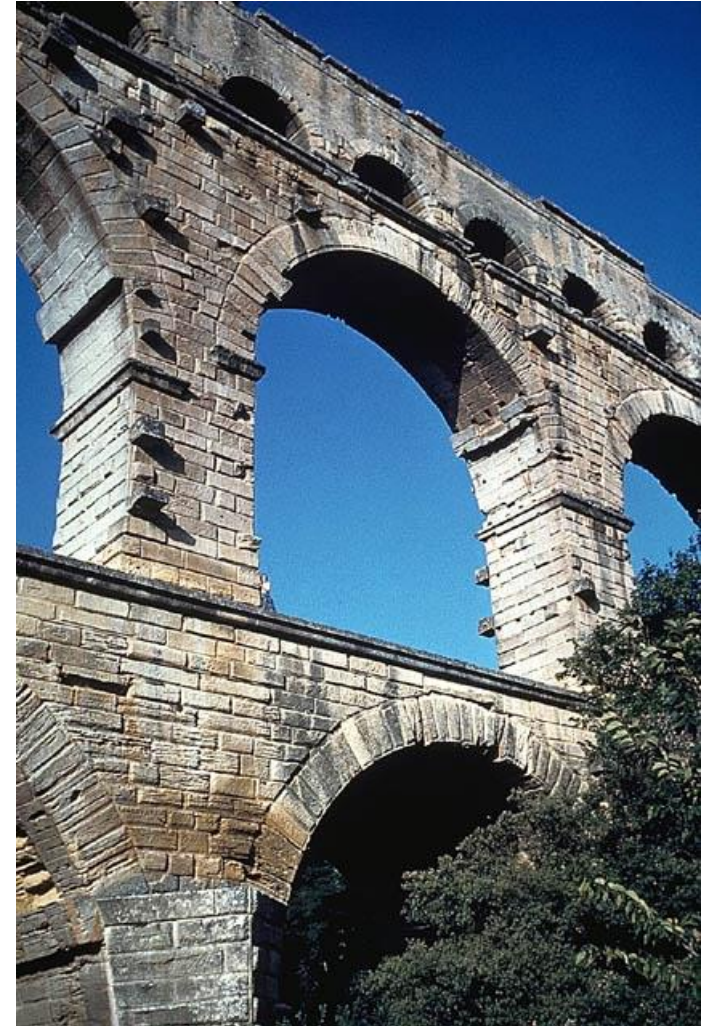



Key Bridge (Georgetown-Reston): 1923



Arch Bridges are currently In Vogue

Frederick Douglass Memorial Bridge, Washington DC (2017-2022)





Science World,
Vancouver, Canada.



Truss

- Combination of square and triangle
 - Both vertical and lateral support

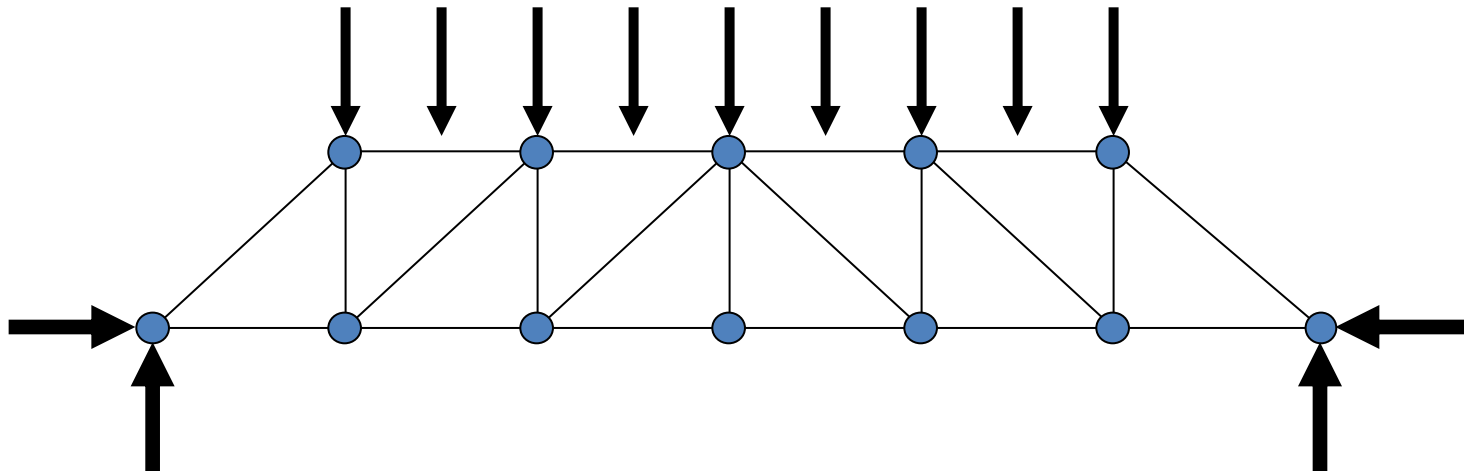

Planar Truss

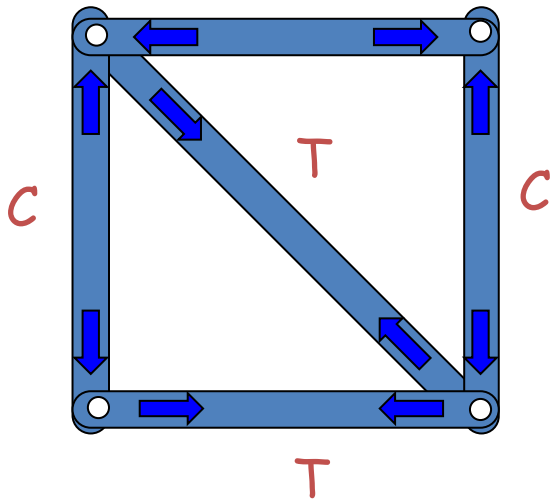
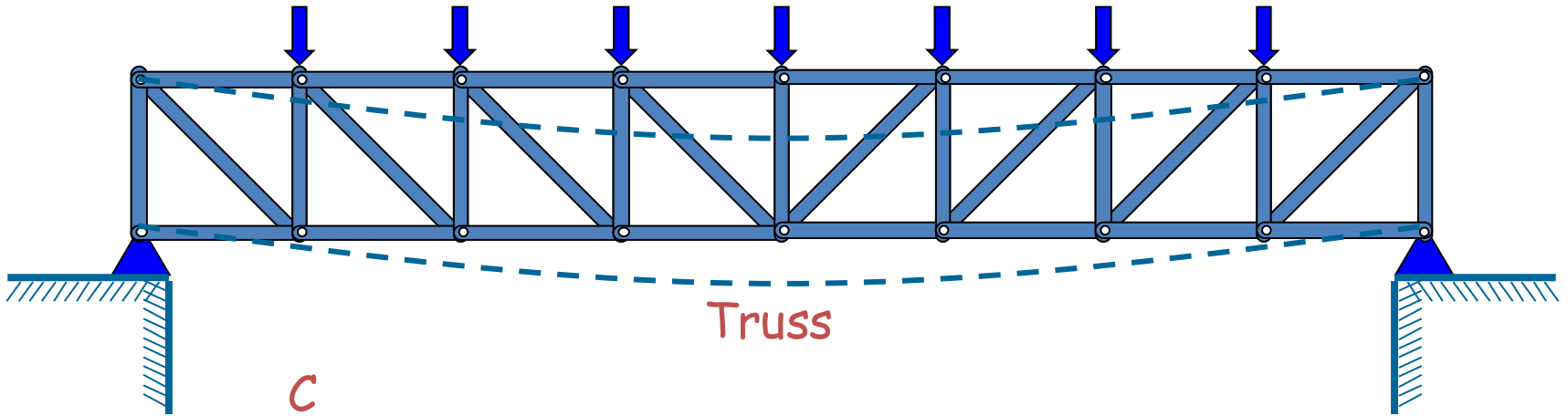

Forces in Truss Members





Three-Dimensional Truss Structure at BWI



Beam/Girder

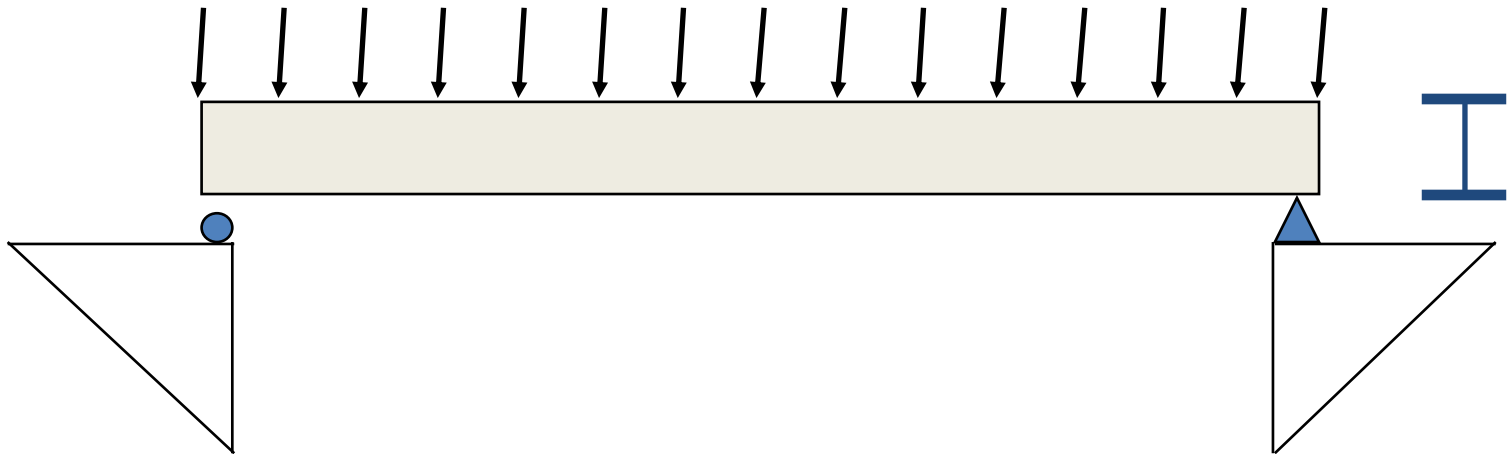



New Computer Science Building at UMD (2017)





Construction of I-95, near Philadelphia, circa 1970.

Frames

Braced

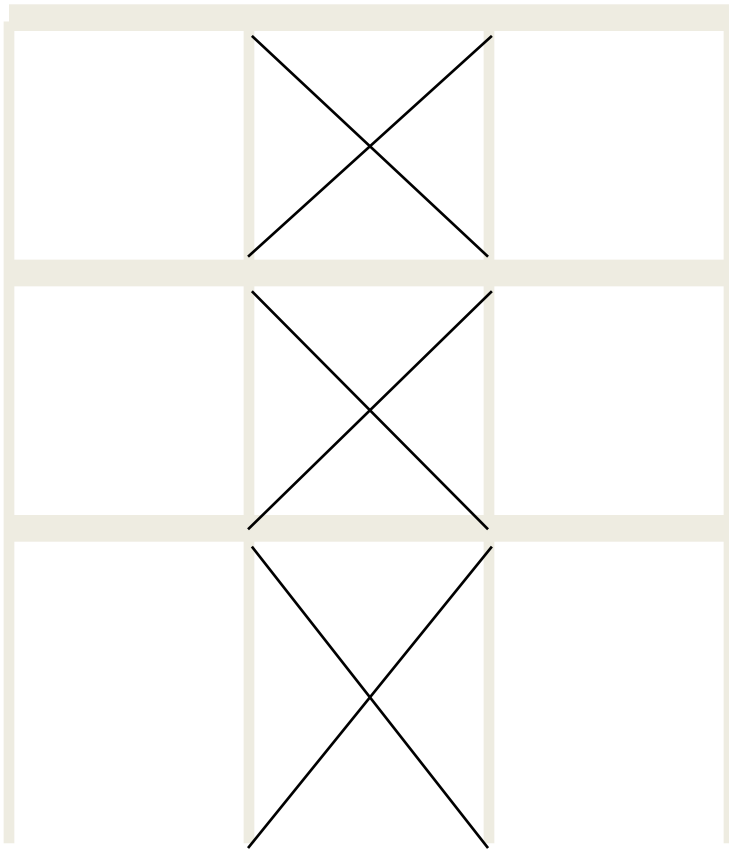

Rigid

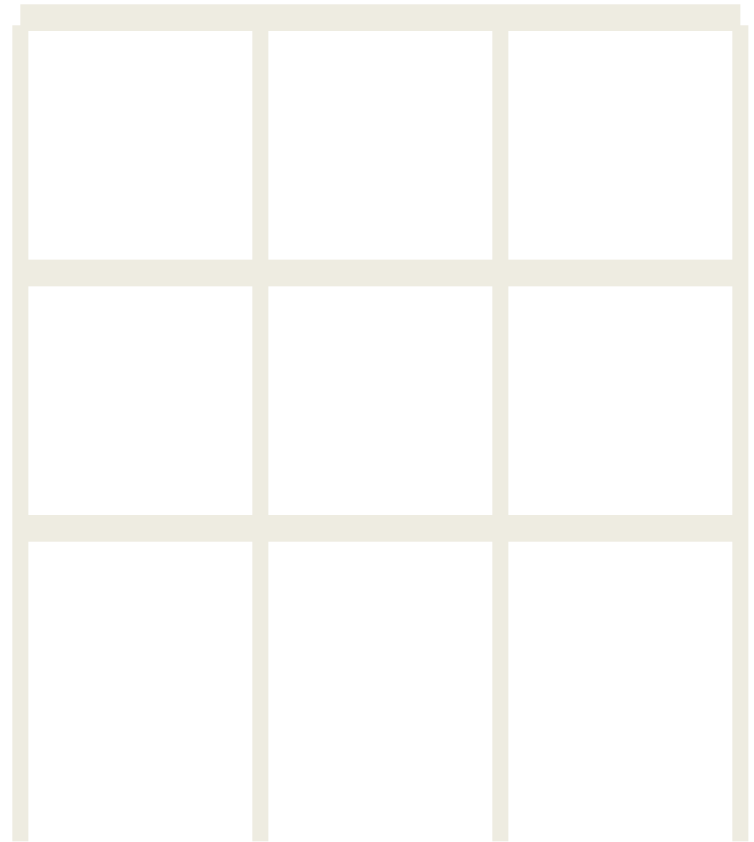

Frames

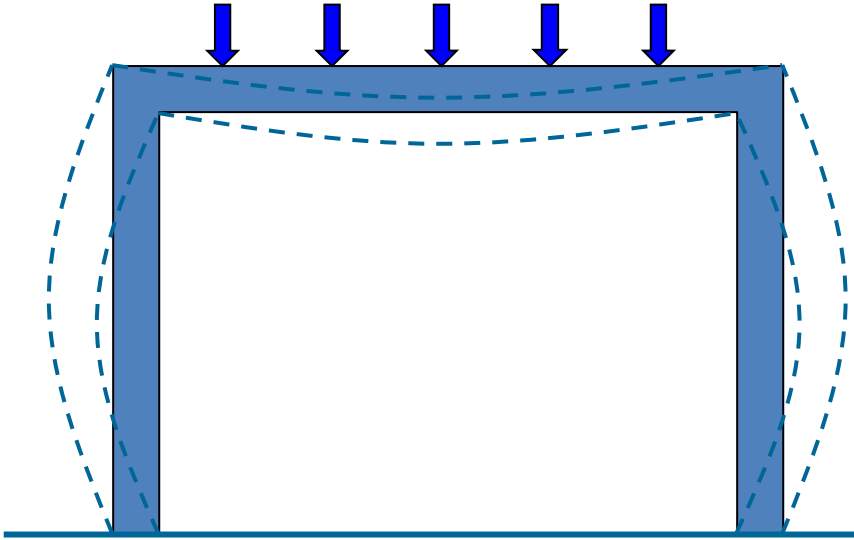

Frame



Analysis objective: We want to compute the distribution of forces – axial, bending moment, shear forces – throughout the structure.

What are the displacements?

Will the frame structure be stable?



Flat Plate

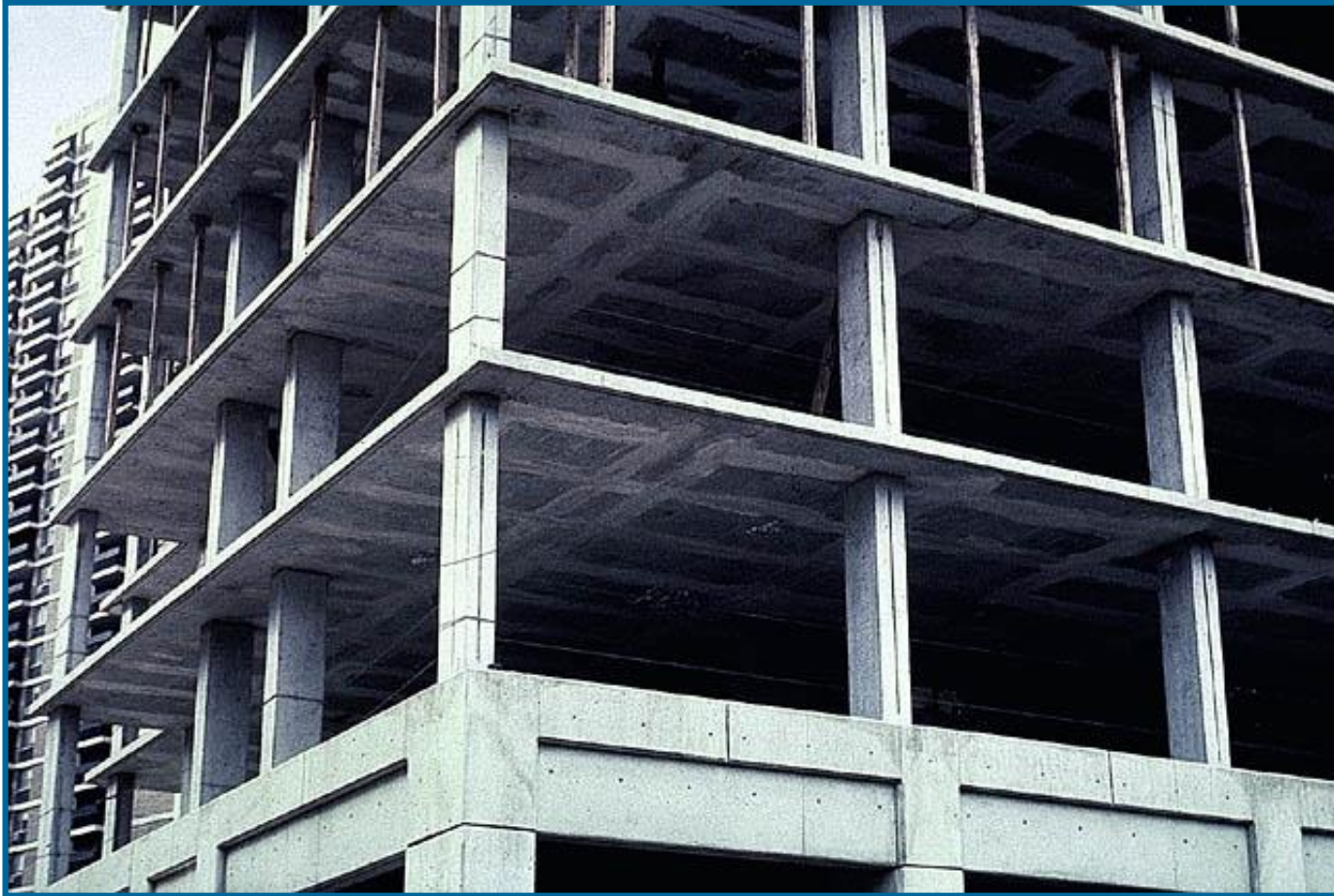

Flat Slab construction at UMD (2024)



Folded Plate



Shells

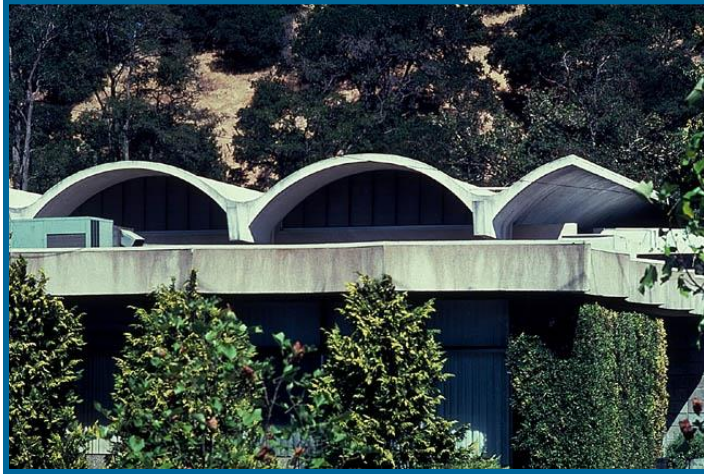

Circular Shell Structure



Lattice Shell Structure

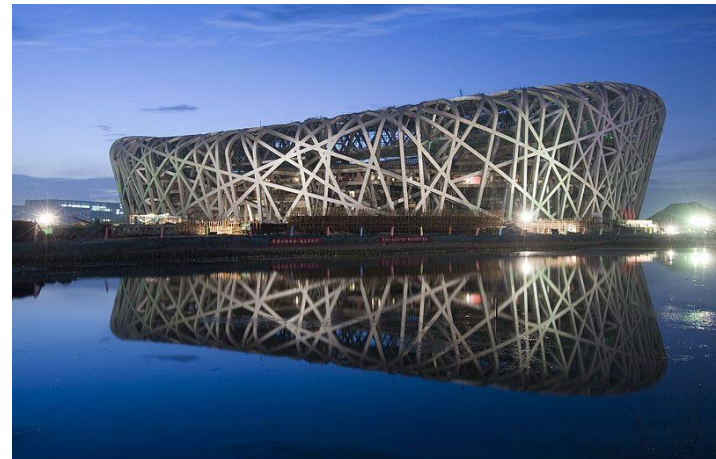

Cable Suspended Structure

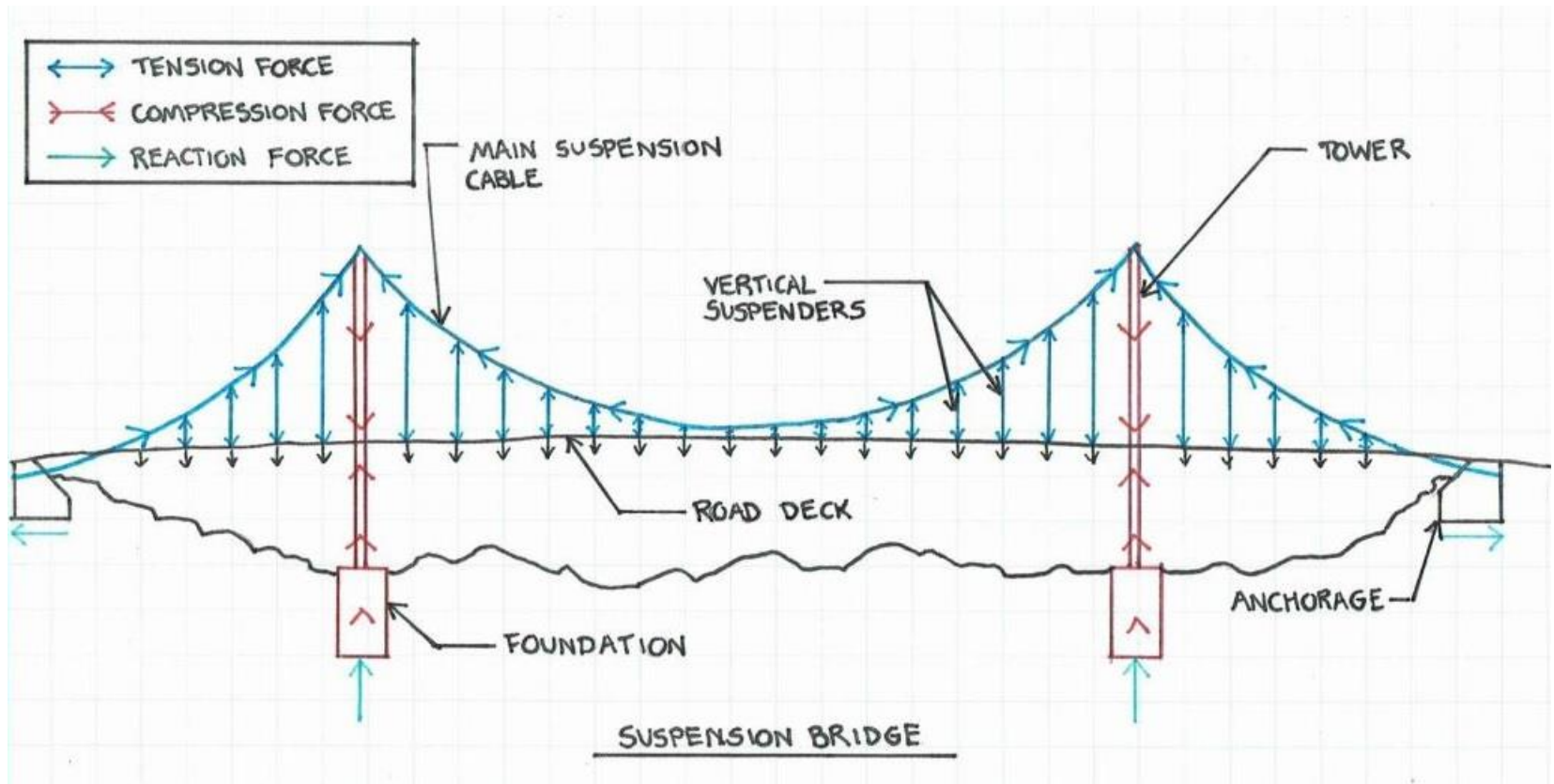

Analysis objectives What are the **forces** in the cable structure? How will the cable **profile shape** change with different **distributions of live load**? What are the **bending moments** in the bridge deck?





GOLDEN GATE BRIDGE
MAIN SPAN
4200 FEET

LENGTH OF OH CABLE 7650 FT. (2331.7m)
DIAMETER OF ONE CABLE . . 36 3/8 IN. (92.4cm)
WIRES IN EACH CABLE 27,572
TOTAL WIRE USED . . . 80,000 MILES (128,748 km)
WEIGHT OF CABLE SUSPENSORS & ACCESSORIES 24,500 TONS (22,226 m.tons)

Cable Contractor : John A. Roebling's Sons Co.
Trenton & Roebling, New Jersey

Power Transmission Lines



Cable Stayed Bridge

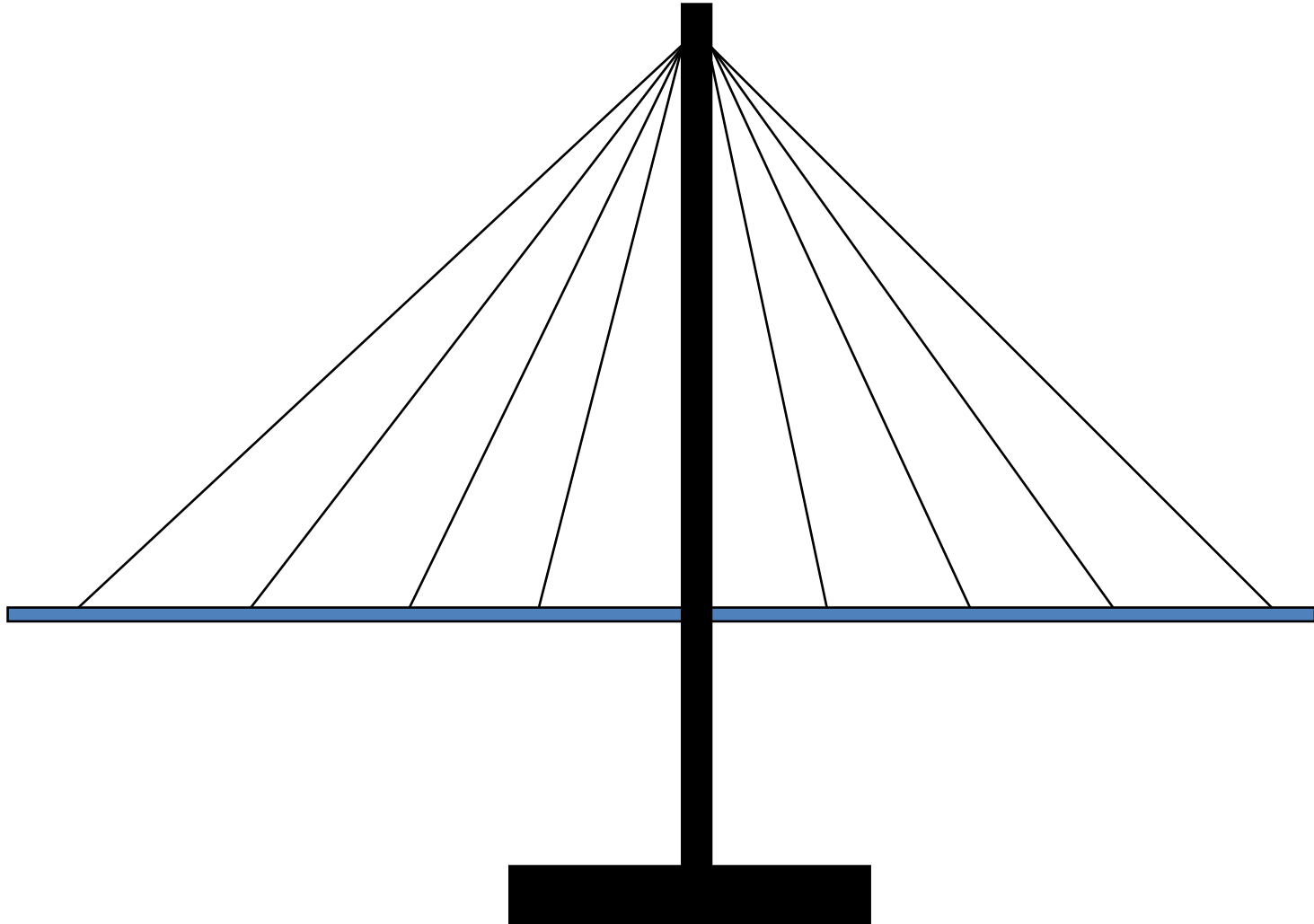

Port Mann Bridge (Vancouver, Canada): Opened 2012



Construction: Kiewit Corporation, 2009-2015.

Bay Bridge East Span (San Francisco-Oakland): Opened 2013

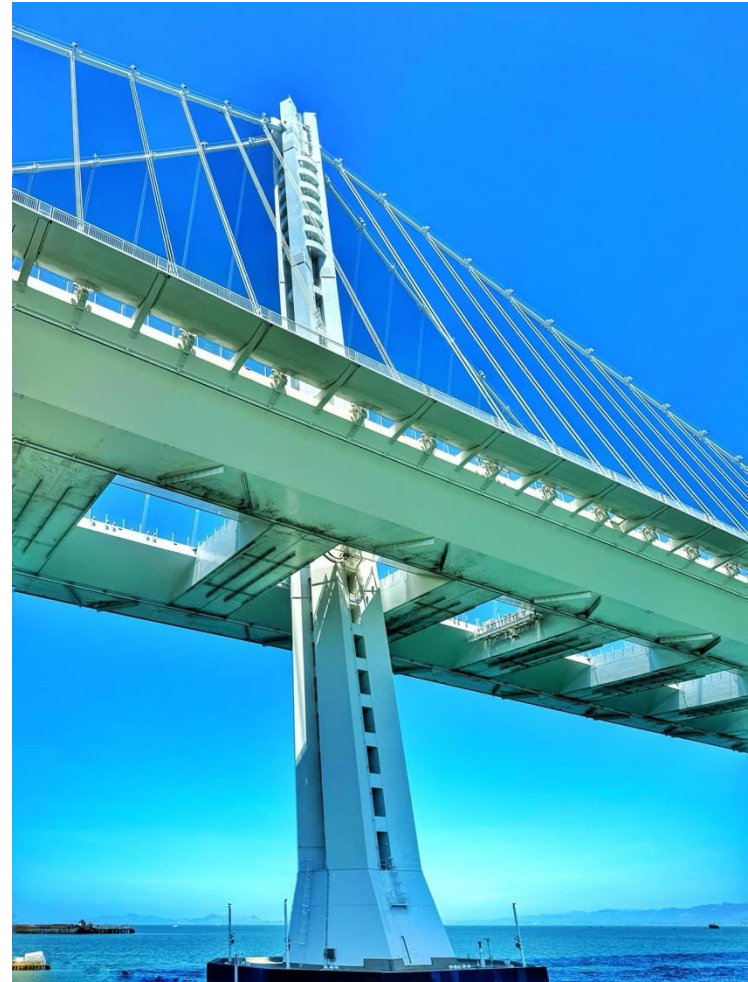

Construction: Kiewit Corporation.

Original budget: \$250M; Final budget: \$6.5B.

Francis Scott Key Bridge Replacement



Tentative Completion: 2030, Budget \$5 billion.

Structural Components and Load Paths

Structural Components

- Beams
- Girders
- Columns
- Floors
- Foundations

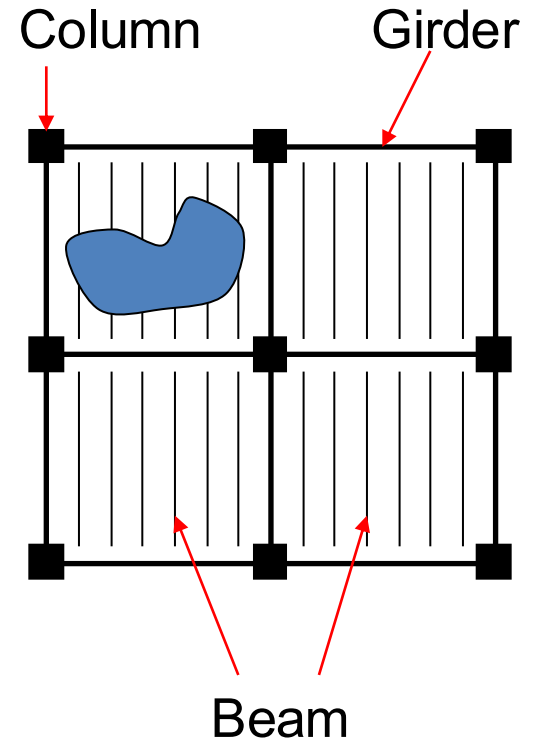
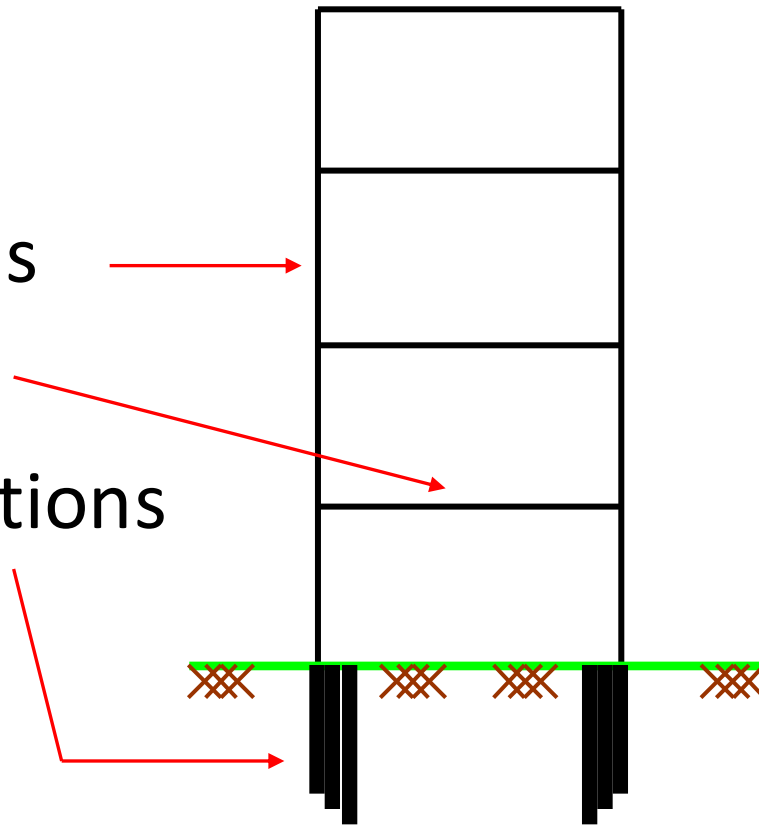

Load Path

- Floor
↓
- Beams
↓
- Girders
↓
- Columns
↓
- Foundation
↓
- Soil/Bedrock

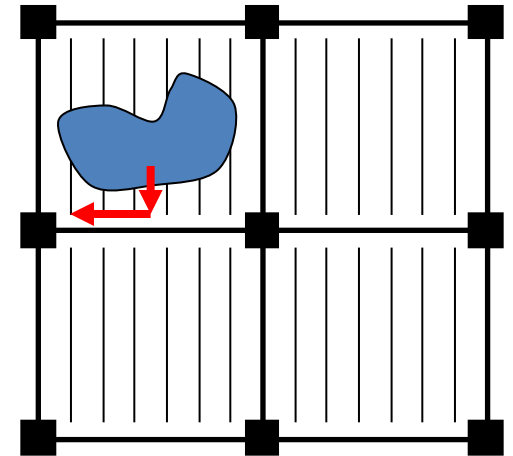
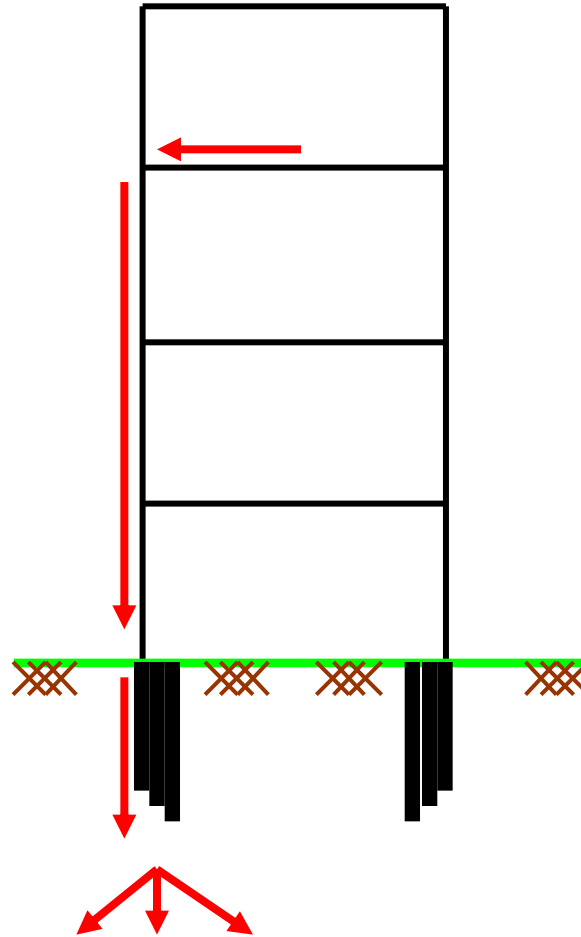

Overview of Structural Behavior

Depends on:

- Material properties (e.g., steel, concrete).
- Structural stiffness (e.g. axial stiffness, bending stiffness)
- Structural strength (e.g., ultimate member strength).

Design challenges (**many tradeoffs to consider**):

- If the **structural stiffness is too low**, then the **displacements will be too large**,
- In dynamics applications a **high structural stiffness** may **attract high inertia forces**.
- If the **structural strength is too low**, then the structural system may **fail prematurely**.

Engineering Properties of Materials

- Steel
 - Maximum stress: 40,000 – 120,000 lb/in²
 - Maximum strain: 0.2 – 0.4
 - Modulus of elasticity: 29,000,000 lb/in²
- Concrete
 - Maximum stress: 4,000 – 12,000 lb/in²
 - Maximum strain: 0.004
 - Modulus of elasticity: 3,600,000 – 6,200,000 lb/in²
- Wood
 - Values depend on wood grade. Below are some samples
 - Tension stress: 1300 lb/in²
 - Compression stress: 1500 lb/in²
 - Modulus of elasticity: 1,600,000 lb/in²

Types of Stress-Strain Behavior

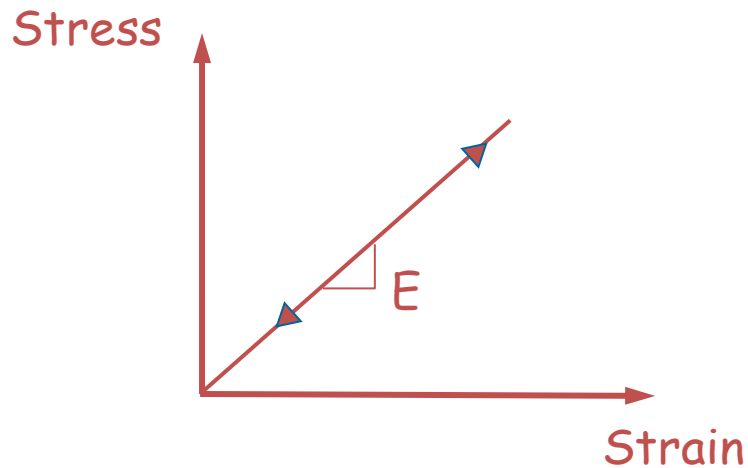

(a) Linear Elastic

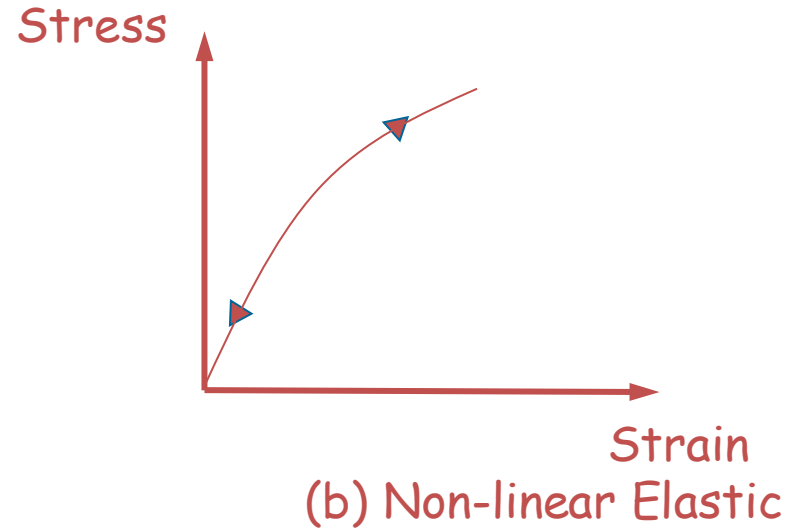

(b) Non-linear Elastic

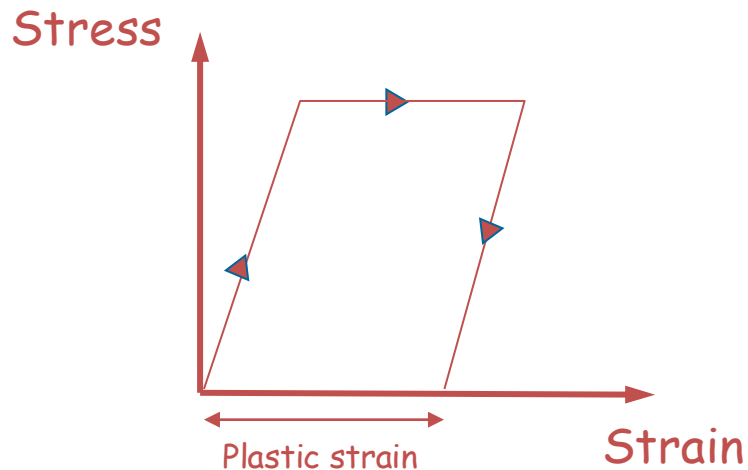

(c) Elastic-plastic

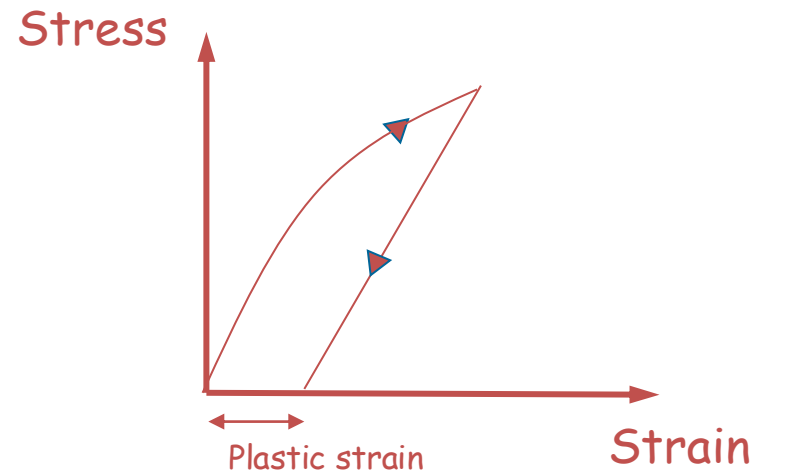

(d) Non-linear Plastic

Engineering Properties of Structural Elements

- Strength

- Ability to withstand a given stress without failure

- Depends on type of material and type of force (tension or compression)

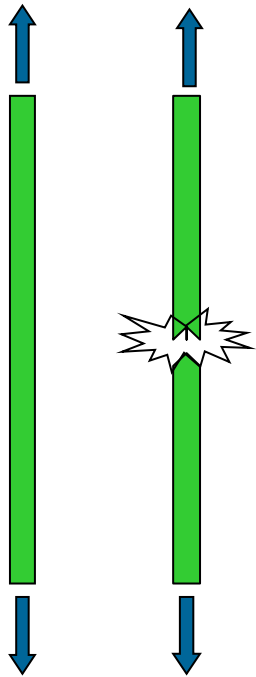

Tensile Failure

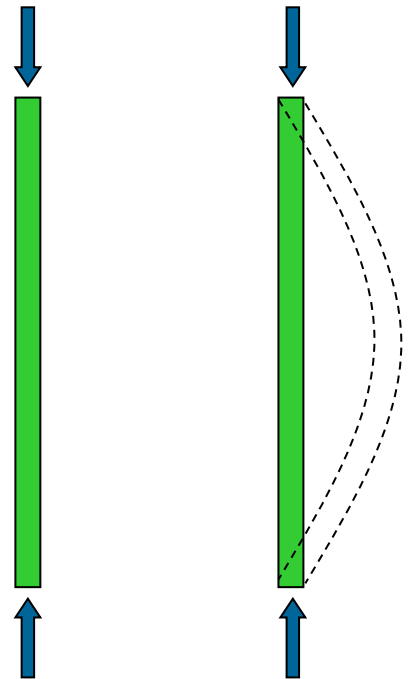

Compressive Failure

Types of Structural Elements – Bars and Cables

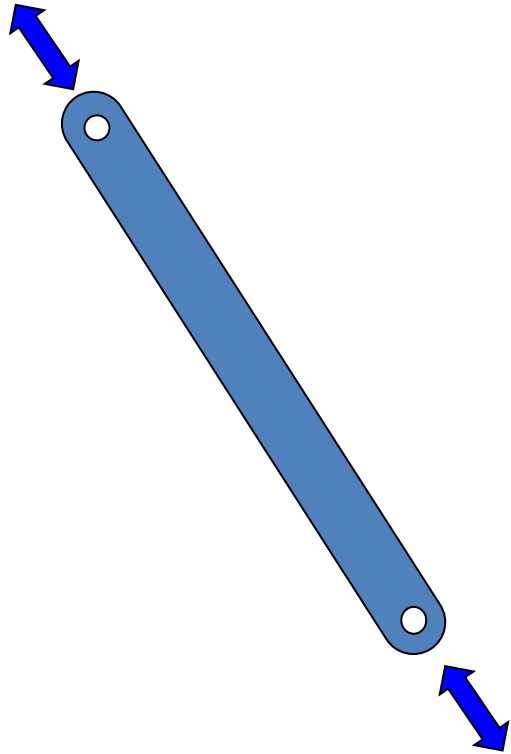

Bars can carry either tension or compression

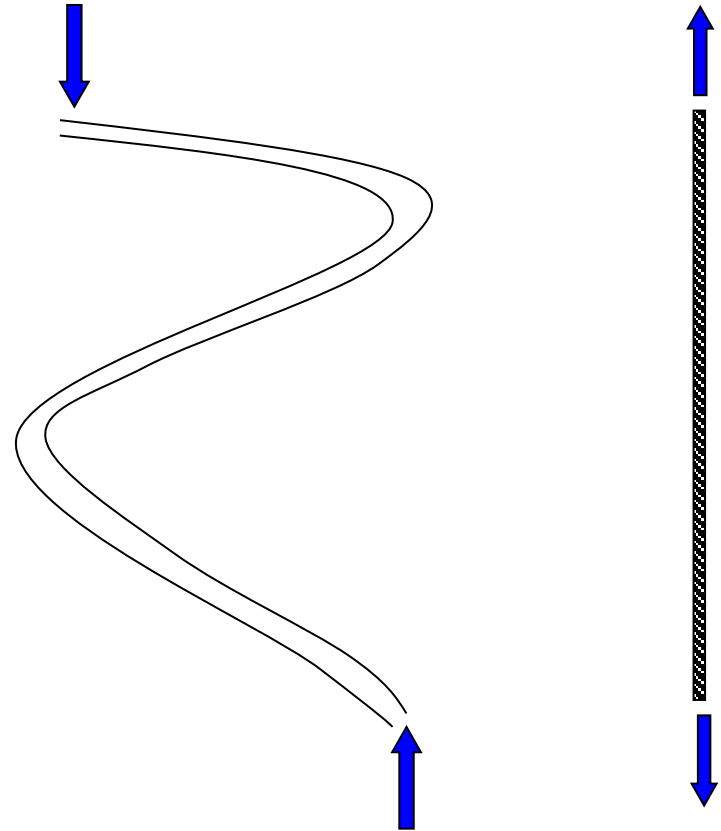

Cables can only carry tension

Types of Structural Elements – Beams

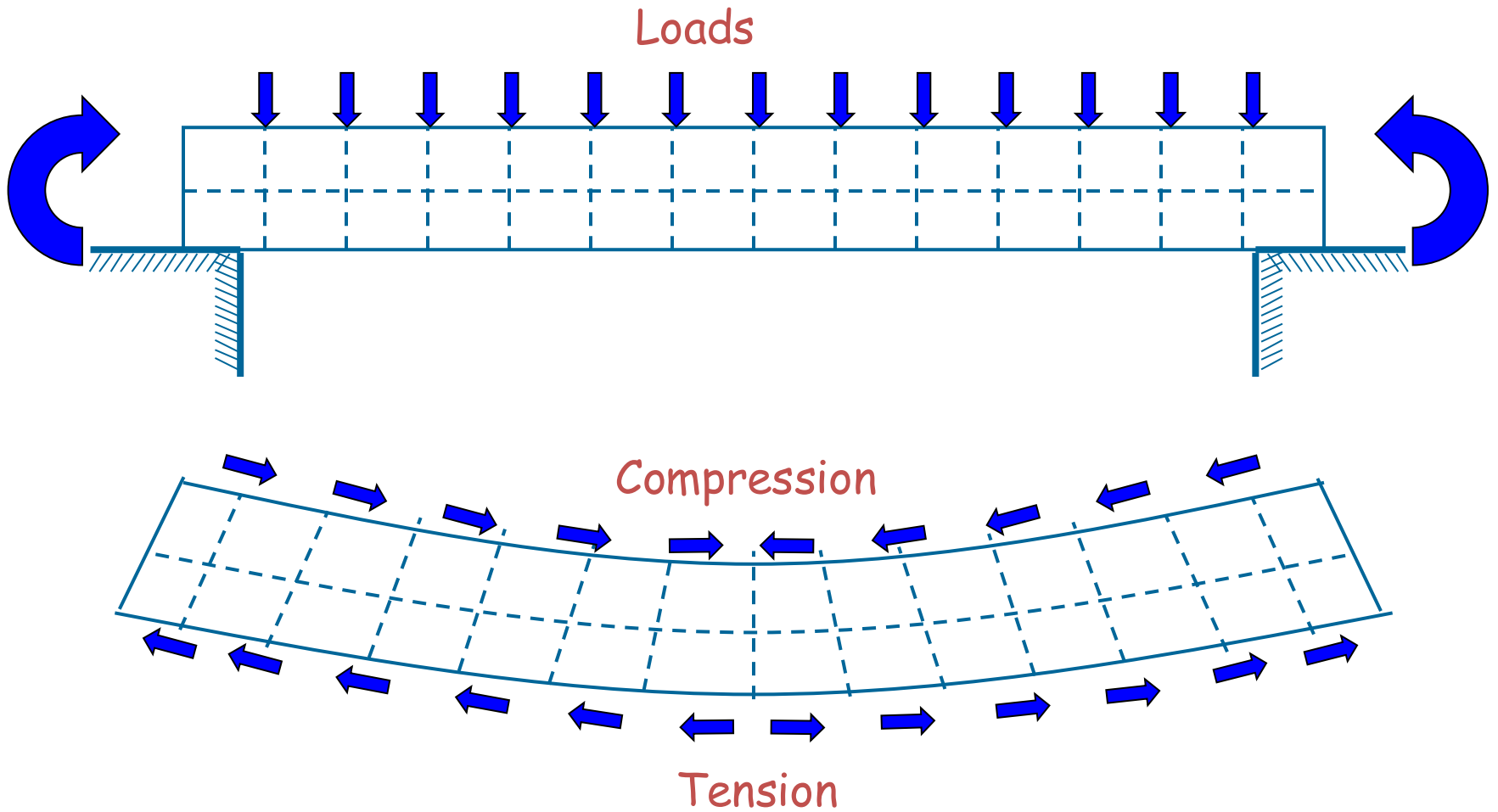

Stiffness of Different Structural Shapes

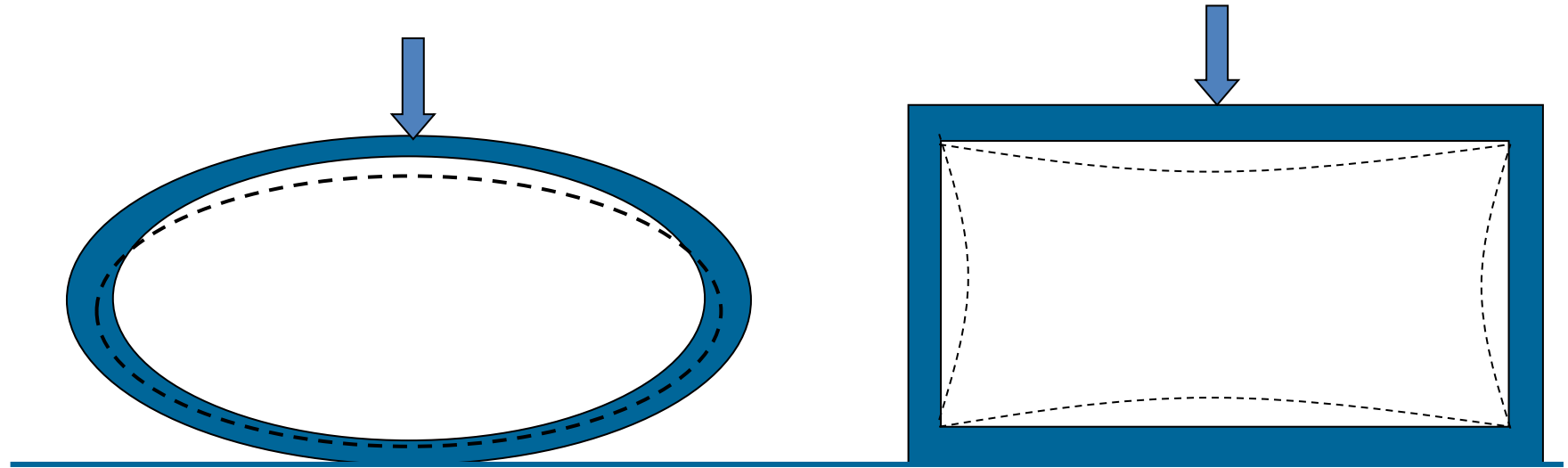

Stiff

Stiffer

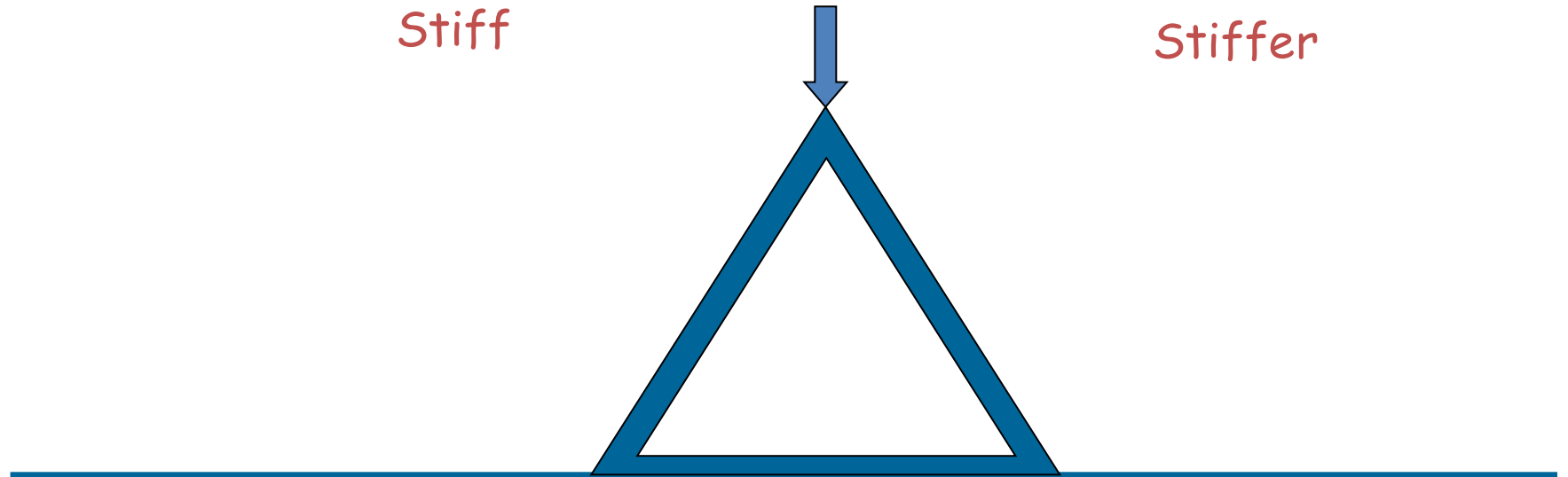

Stiffest

Providing Stability for Lateral Loads

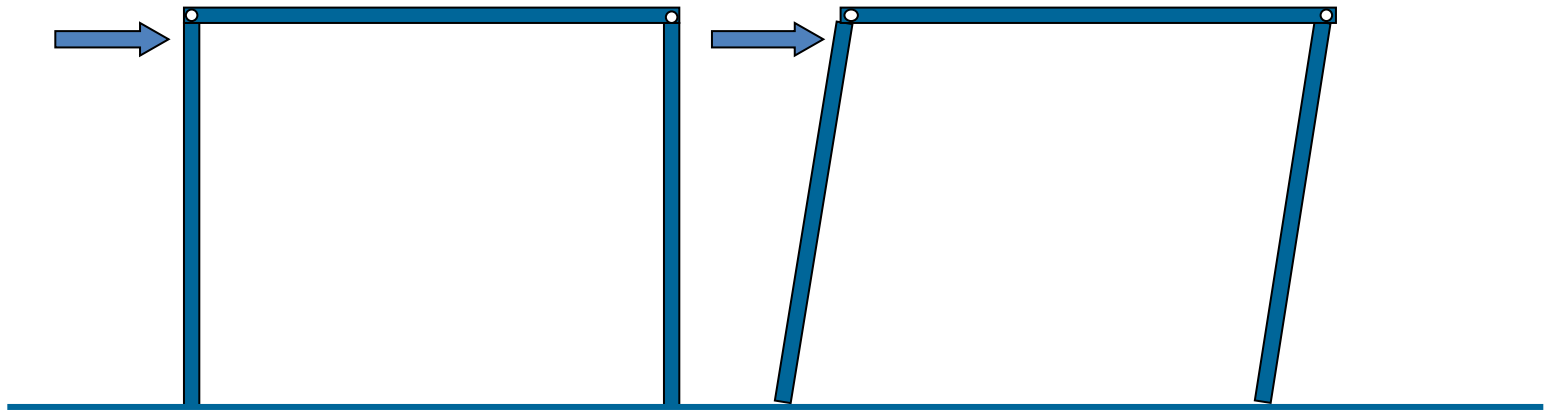

Racking Failure of Pinned Frame

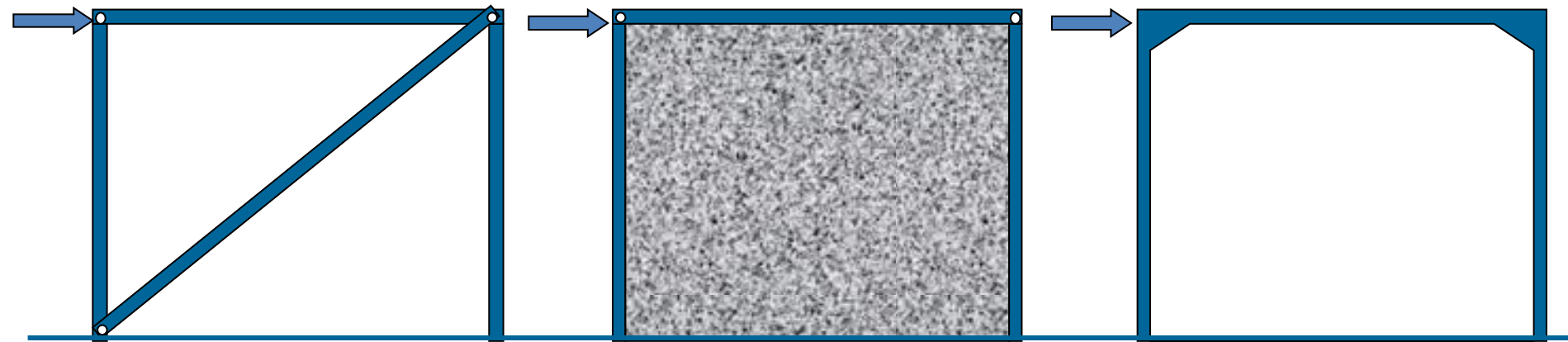

Braced Frame

Infilled Frame

Rigid Joints

Failure Mechanisms

Structural failure refers to **loss in the load-carrying capacity** of a component or member within a structure.

Failure is initiated when the material is stressed to the strength limit, thus causing fracture or **excessive deformations**.

Ultimate failure is usually associated with **extreme events**.

The structural engineer needs to **prevent loss of life** by prohibiting total collapse of the structural system.

Failure due to Dynamic Instability

Failure to understand aeroelastic flutter can be catastrophic.

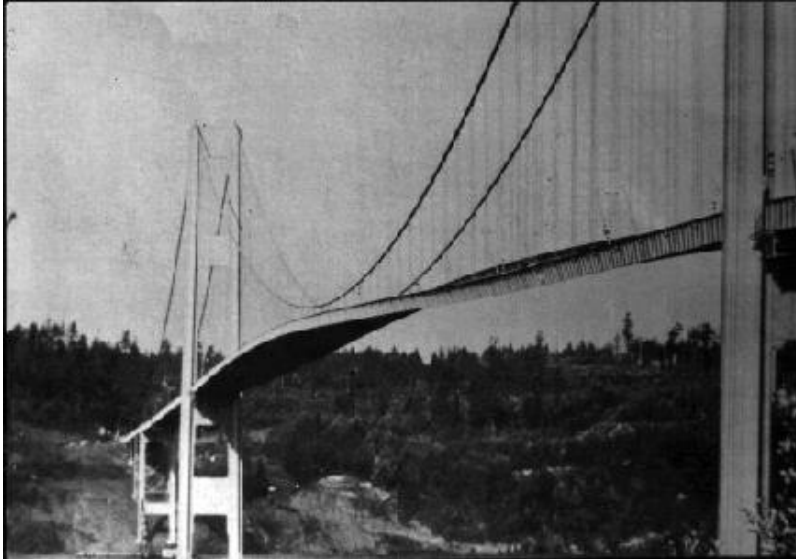

The Tacoma Narrows bridge opened in July 1940 and collapsed a few months later (November 1940) in a 40 mph wind.

Failure completely changed the way in which suspension bridges are analyzed and designed.

Failure due to lack of Ductility in Concrete Columns



Frame buildings can have also be built with concrete columns and beams (as opposed to steel)

1971 San Fernando earthquake showed that many concrete frames were brittle

Potential for collapse at drifts of about 0.01 (lower than for steel buildings)

There are thousands of these buildings in California and occupants have not been notified

Olive View Hospital
M 6.7 1971 San Fernando Earthquake

Northridge 118 FWY

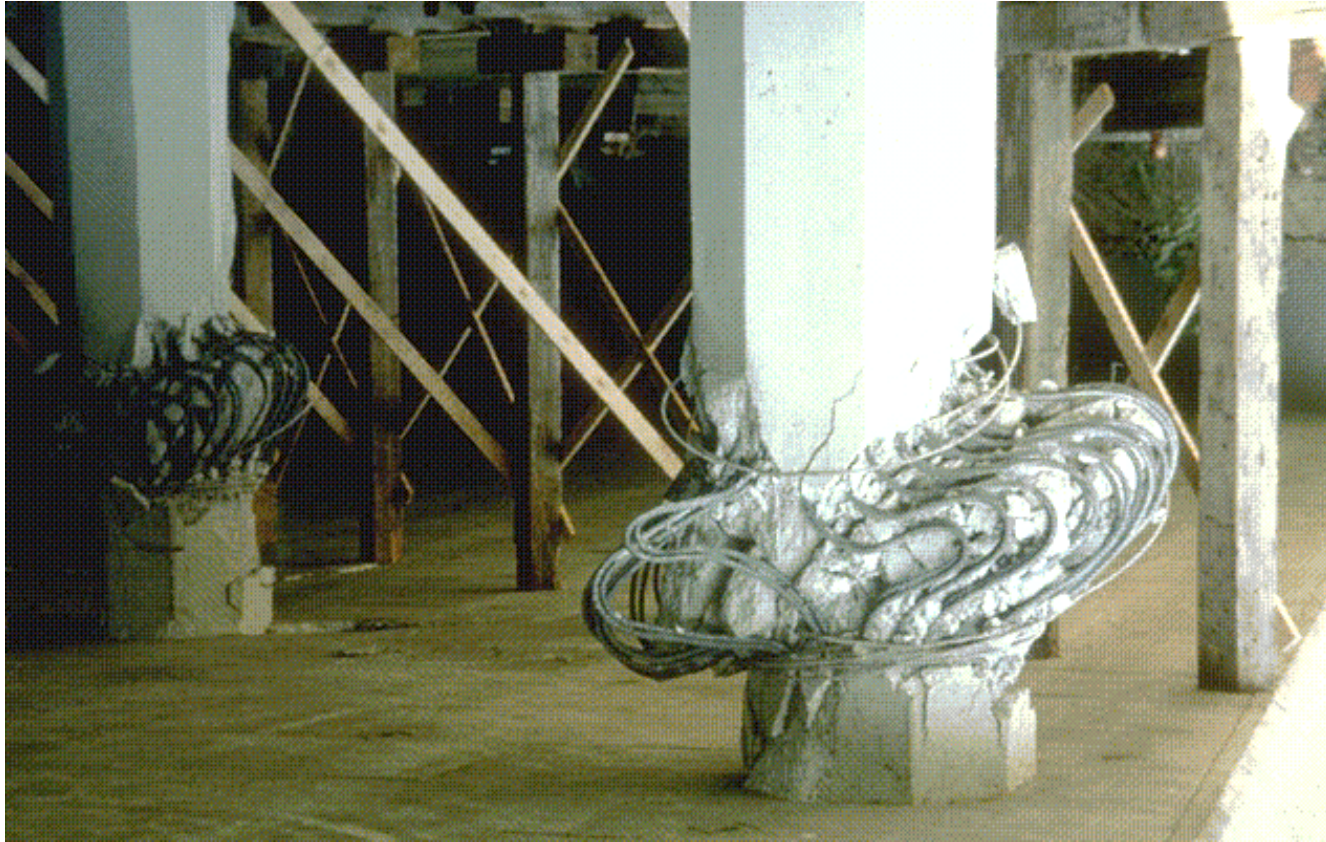

Example of failure of a brittle concrete column (pre-1975 code)



Example of “ductile” behavior of concrete columns. Although the parking structure performed poorly, the exterior columns did not fail.

Mexico City Earthquake, 1996



CUREe

11 years ago... Mexico Earthquake, September 19, 21-story building collapsed onto 14-story neighbor, Pino Suarez complex photo credit: Henry Desenkolb

1996

Soil liquefaction

stable soil



Building stands erect on stable soil.

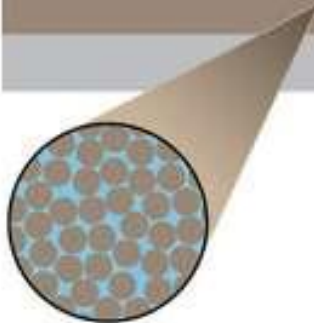

Loosely packed grains of soil are held together by friction. Pore spaces are filled with water.

liquefied soil

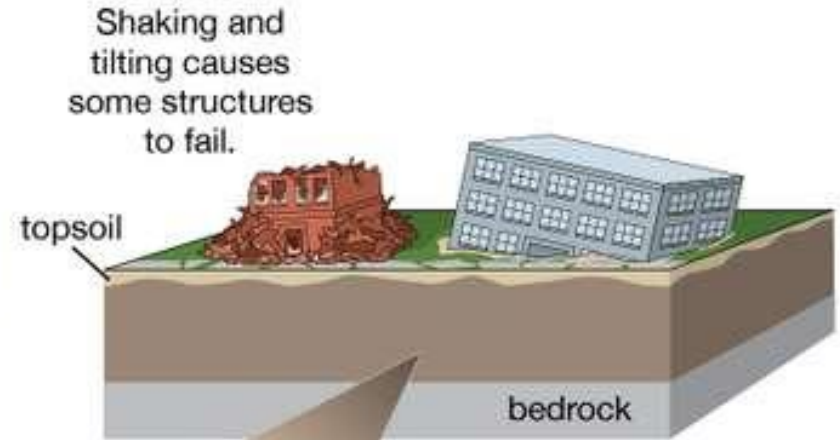

Building tilts and sinks as soil stability declines.

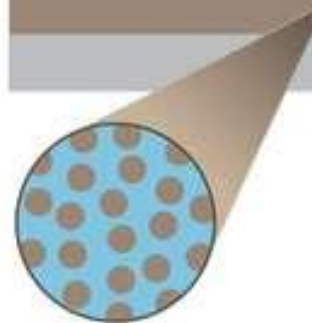

Shaking destabilizes the soil by increasing the space between grains. With its structure lost, the soil flows like a liquid.

© 2012 Encyclopædia Britannica, Inc.

YouTube Search: liquefaction

San Francisco Earthquake, 1906

Failure due to liquefaction in Japan



CUREe

35 years ago...Niigata, Japan Earthquake, June 16, 1964: Liquefaction and resulting overturning of buildings at the site of an apartment complex in Niigata.

photo by Joseph Penzien, Steinbrugge Collection/National Information Service for Earthquake Engineering

1999

Sometimes you are simply in the wrong place at the wrong time ...



Christchurch, New Zealand, 2011.

Richter Magnitude = 6.3

Failure of the Christchurch Cathedral...



Sometimes extreme events spur real innovation!

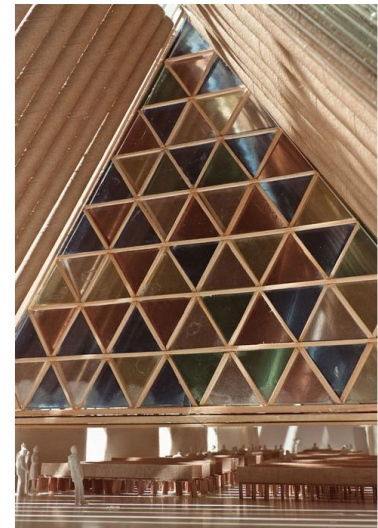

Summary

- Structural Engineering:
 - Identifies loads to be resisted
 - Identifies alternatives for providing load paths (arch, truss, frame, ...)
 - Designs structure to provide safe and economical load paths (material, size, connections)
 - To be economical and safe, **we must be able to predict what forces are in structure.**

Acknowledgement: University of Massachusetts Amherst