

ASSIGNMENT II

Due: March 22, 2006 (during class)

NO EXCEPTIONS: I will accept *no* faxed or emailed copies

DIRECTIONS

1. In accordance with syllabus policy (page 2, section on Academic Integrity) in order to receive credit for this assignment you must adhere to the instructions set forth in this assignment, as explained in these directions. Moreover, you must attach this page to the assignment, as a cover sheet, signed and dated. If you emailed the assignment to me, you must still hand in this signed and dated document, in order to receive credit.
2. You may consult with the instructor, the notes you took in class, and any text or URL. You may also consult with your fellow classmates, if you choose, *but* the solutions to the problems must be written up by your own hand individually. (In other words, ‘consulting’ here doesn’t mean copying what your fellow classmate does without understanding what you’re copying.) You may not, however, consult with any other faculty member at Capitol College or elsewhere. If you consulted any references, you should cite. Please adopt the following format when citing:

(Example)

“According to Eqn 1 [*Jones* (1992), 11] ...”

...where the complete reference of *Jones* is found in your list of references, stapled at the end of the assignment. The page number follows the date (in parentheses). Though standards in technical writing vary, I would prefer you list a citation in the following format:

Example for a book:

Jones, Robert. *Elementary Linear Algebra*. (Boston: Harcourt Press, 1992)

Example for an article:

Jones, Robert. “Boundary Value Equations: An Overview”. *American Mathematical Monthly*, vol. 3 n2 (1998), 1227-1135.

Example for an electronic source, (website, pdf or other):

Jones, Robert.(2003 – use date it was last updated if it is a webpage) “Some Properties of Orthogonal Functions” URL = <[http://www.jrworld.org/~jroberts/...](http://www.jrworld.org/~jroberts/) >

Please use discretion when citing. If you stumble across a formula in some source, which I have asked you to explicitly derive, you obviously cannot cite it. This is taken care of by the fact that you must show all your work in maximal reasonable detail. An answer with no work shown gets a 0.

I have read, understood, and have complied with the instructions set forth in this assignment

(Signature) (date)

Directions: Please complete the following problems listed below. Start each problem on a fresh sheet of paper, in legible and neat form. Illegible work will not be graded, and marked with a 0 grade.

I. (20) Find the inverse LT

(a) (10) Exercise 19 (p 69 Sheng)

(b) (10) $F(s) = \frac{5s^2 - 15s + 7}{(s+1)(s-2)^3}$

II. (20)

(a) (10) Exercise 8 (p 80 Sheng) *without* using LTs

(b) (10) Repeat a) using LTs. Show that your answers are identical

III. (30)

(a) (10) Problem 2(d) Exercise 8 (p 86 Sheng)

(b) (20) Solve the following IVP (Initial Value Problem) using LTs:

$$\frac{d^4 y(t)}{dt^4} + 2 \frac{d^2 y(t)}{dt^2} + y(t) = \sin t; y(0) = 1, y'(0) = -2, y''(0) = 3, y'''(0) = 1$$

IV. (30)

(a) (15) Exercise 7 (p 101 Sheng) using LTs

(b) (15) Given the circuit below:

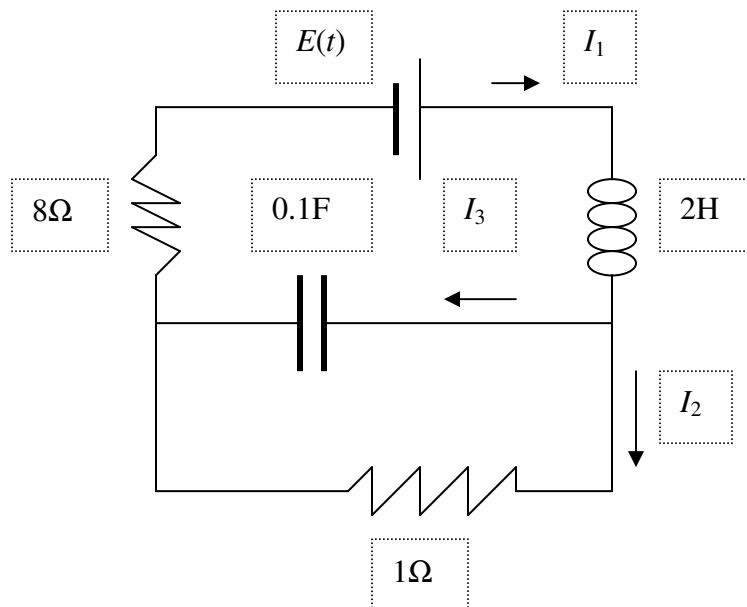

Find the currents and the charge $Q(t)$ in the capacitor if $E(t) = 600e^{-5t} \sin 3t$
 Assume all initial charges and currents = 0 at $t = 0$

BONUS: Given an external force $F(t)$ acting on a vertical spring (see figure below) and a restoring force $-\kappa x$ as well as resistive force: $-\beta \frac{dx}{dt}$:

- a.) (5 pts) Use Newton's Second law to write the differential equation for this system (assume $x(0) = x'(0) = 0$)
- b.) (15) Use LTs and THM12 to solve for a)

